

Safety



Dixon's couplings and retention devices are designed to work safely for their intended use. The selection of the proper hose, coupling and retention device, and the proper application of the coupling to the hose are of utmost importance.

Users must consider the size, temperature, application, media, pressure and hose and coupling manufacturer's recommendations when selecting the proper hose assembly components. Dixon recommends that all hose assemblies be tested in accordance with the Association for Rubber Products Manufacturer's (ARPM) recommendations and be inspected regularly (before each use) to ensure that they are not damaged or have become loose. Visit ARPMINC.com for more information.

Where safety devices are integral to the coupling, they must be working and utilized. The use of supplementary safety devices such as safety clips or safety cables are recommended.

If any problem is detected, couplings must be removed from service immediately.

Dixon is available to consult, train and recommend the proper selection and application of all fittings we sell. We strongly recommend that distributors and end users make use of Dixon's Testing and Recommendation Services. Call 877.963.4966 or click dixonvalve.com to learn more.

Features and Benefits

- Full 360° rotational movement offers maximum flexibility
- Wide spacing between dual ball bearing raceways ensures greater load-bearing capacity
- Precision-machined design ensures alignment and years of trouble-free service
- An O-ring dust seal protects the ball races and seal chamber from outside elements.
- The radius elbow design ensures a smooth flow pattern

*All weights and dimensions are approximate and subject to change without notice.
Consult the factory when critical.*

Color Coding System for Seal Identification:

BU *Buna-N* - red stripe
VI *FKM* - green stripe
TF *PTFE* - natural
EP *Ethylene Propylene* - green and white stripes

Swivel Styles

O-Ring Style Swivels

- The O-ring pressure seal ensures a leak-proof seal and smoother rotation at lower torques than multiple designs.
- Spring-loaded PTFE pressure seals are available through 3"
- Carbon steel and stainless steel O-ring type swivels provide greater strength and corrosion resistance when needed for lower torque applications

V-Ring Style Swivels

- The spring-loaded triple V-ring sealing system ensures a leak-proof seal and an extended seal life compared to the conventional single O-ring design.
- The 3" - 8" carbon steel swivels are manufactured from carbon steel with flame hardened dual raceways for greater load bearing capacity and longer life.
- Stainless steel swivels are manufactured in 316 grade stainless steel for superior corrosion resistance.

Flange Bolt Tightening Sequence (use appropriate gaskets and bolts)

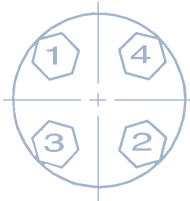

4 Bolt

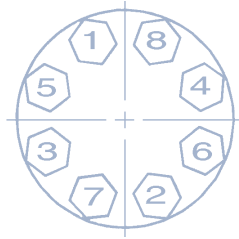

8 Bolt

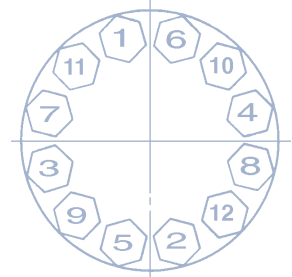

12 Bolt

Dimensions of 150 lb. ASA Steel Flanges

Nominal Pipe Size	Flange O.D.	Thickness *	OD of Raised Face	Diameter of Bolt Circle	Number of Bolts	Diameter of Bolt Holes	Diameter of Bolts
1"	4-1/2"	9/16"	2"	3-1/8"	4	5/8"	1/2"
1-1/2"	5"	11/16"	2-7/8"	3-7/8"	4	5/8"	1/2"
2"	6"	3/4"	3-5/8"	4-3/4"	4	3/4"	5/8"
2-1/2"	7"	7/8"	4-1/8"	5-1/2"	4	3/4"	5/8"
3"	7-1/2"	15/16"	5"	6"	4	3/4"	5/8"
4"	9"	15/16"	6-3/16"	7-1/2"	8	3/4"	5/8"
5"	10"	15/16"	7-5/16"	8-1/2"	8	7/8"	3/4"
6"	11"	1"	8-1/2"	9-1/2"	8	7/8"	3/4"
8"	13-1/2"	1-1/8"	10-5/8"	11-3/4"	8	7/8"	3/4"
10"	16"	1-3/16"	12-3/4"	14-1/4"	12	1"	7/8"
12"	19"	1-1/4"	15"	17"	12	1"	7/8"

* 1/16" raised face is included in the thickness

Flange Diagrams

Threaded Applications

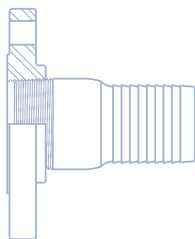

threaded flange with raised face

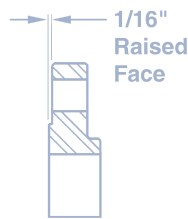

1/16" Raised Face

Welded Applications

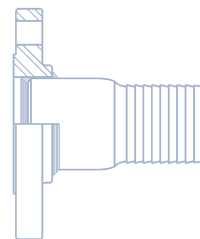

slip-on flange with raised face

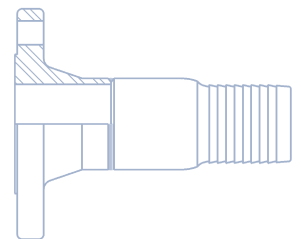

weld neck flange with raised face

Floating Applications

(flange free to swivel)

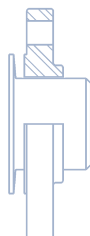

slip-on flange with raised face

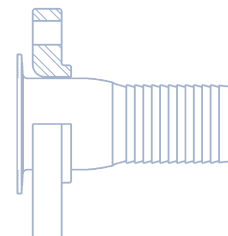

lap-joint flange

Operation / Service

Dixon swivels are recommended for use at the following maximum Non-Shock Cold Working Pressures (NSCWP) provided in PSI, at ambient temperatures (70°F).

	(V-Ring) Carbon Steel CS	(O-Ring) Carbon Steel OC	(V-Ring) Stainless Steel SS	(O-Ring) Stainless Steel OS	Aluminum AL	Brass BR	Malleable Iron MI
1"	---	1000	---	1000	150	---	---
1¼"	---	---	---	---	150	---	---
1½"	---	1000	---	1000	150	300	600
2"	1000	1000	1000	1000	150	300	600
3"	1000	1000	1000	1000	150	300	600
4"	1000	---	1000	---	150	---	---
6"	1000	---	---	---	150	---	---
8"	---	---	---	---	150	---	---

- When using flanged ends, the pressure rating will be reduced to coincide with that of the flange being used. Carbon steel and stainless steel 150# flanges are recommended for use at 275 maximum PSI at ambient temperature (70°F).
- Lubrication should be performed periodically, depending on service and operation conditions. Twice yearly is normally sufficient.
- All dimensions are approximate. Where critical, consult the factory.

Options Available:

- Any combination of end configurations
- Alternative seal materials: FKM, PTFE, Ethylene Propylene and FDA Buna
- Alternative ball bearing materials: 440 stainless steel and 316 stainless steel
- Alternative grease materials: FDA approved/food grade and silicone
- Drain holes or counter balance lugs
- Swivels for oxygen service, steam service and submerged service can be specifically designed for unique applications (special order)

Use with Hose

The use of swivel joints to compensate for twist in hose (i.e. Style 20 or Style 60) should be carefully reviewed, since the hose must be sufficiently stiff to generate the torque needed to actuate the swivel before it kinks.

In many installations, the twist is caused by lateral movement that can be eliminated by the use of a swivel joint that addresses the lateral movement (i.e. Style 40 or Style 30).

Where this is not possible, the use of hose swivels may be a solution. Hose swivels are generally non-ball bearing designs that require less torque to initiate rotation; however, hose swivels are not designed for load bearing service.

Some hoses are unable to generate even the low torque required for a hose swivel, many metal hoses fall into this group. Other hoses are stiff enough to turn almost any swivel, many armored hoses fall into this group.

Pricing

All pricing available upon request. Please contact factory for pricing and proper equipment selection for the correct application.

Every swivel joint is built to order, due to this, they are not generally returnable. Return requests will be reviewed on a case by case basis. Restocking charges will be applicable on all returns. Restocking charges include 15%, plus any additional costs incurred.

Ordering Information - Swivels

To select the proper swivel joint you need the following information:

Size: _____ Style (shape): _____

End Configuration: _____ Material: _____

Maximum Working Pressure: _____ Temperature Range: _____

Product being handled: (if a chemical, please advise concentration) _____

If for constant rotation, advise RPM: _____

If for suction service, advise maximum vacuum in inches of Mercury (Hg): _____

Our factory sales and engineering staff will be happy to help you evaluate your swivel application. Please call 800.355.1991.

	<i>swivel size</i>	<i>swivel style</i>	<i>end configuration</i>		<i>end configuration</i>	<i>swivel material</i>	<i>pressure seal (Buna-N standard)</i>	<i>dust seal (Buna-N standard)</i>	<i>retainers (V-Ring ONLY)</i>	<i>ball bearings (carbon steel standard)</i>	<i>grease</i>
Example	<u>2</u> [A]	<u>20</u> [B]	<u>F</u> [C]	X	<u>F</u> [C]	<u>CS</u> [D]	<u>0</u> [E]	<u>0</u> [F]	<u>1</u> [G]	<u>0</u> [H]	<u>0</u> [I]

- [A] Size
- [B] Style (see diagrams)

[C] End Connections	W Weld End	F Female End	FG 150# ASA Flange	TF Tank Truck Flange	PF 300# ASA flange (not available on aluminum)
[D] Material	CS (V-Ring) carbon steel	SS (V-Ring) stainless steel	AL aluminum	BR brass	MI malleable iron
	OC (O-Ring) carbon steel	OS (O-Ring) stainless steel			

Code #	[E] Pressure Seal	[F] Dust Seal	[G] Retainers	[H] Ball Bearings	[I] Grease
0	Buna-N (standard)	Buna-N (standard)	No retainers (O-ring swivels)	Carbon steel (standard)	Standard
1	FKM	FKM	Aluminum (standard in CS V-ring)	440 grade stainless	FDA approved/ Food grade
2	PTFE	---	PTFE (standard in SS V-ring)	316 grade stainless	Silicone (required with EPR seals)
3	Ethylene Propylene (requires silicone grease)	Ethylene Propylene (requires silicone grease)	---	---	---
4	FDA Buna (O-ring only)	FDA Buna	---	---	---

The swivel should be packed so that the surfaces coming in contact with the fluid being handled are compatible with that fluid. *In the case of the use of the swivel in submerged service this would include the dust seals and ball bearings.*

Dixon always recommends the use of stainless steel ball bearings when building a swivel for submerged service since the standard carbon steel bearings could rust together making it impossible to disassemble the swivel and possibly affecting its operation.

V-Ring Parts Identification List

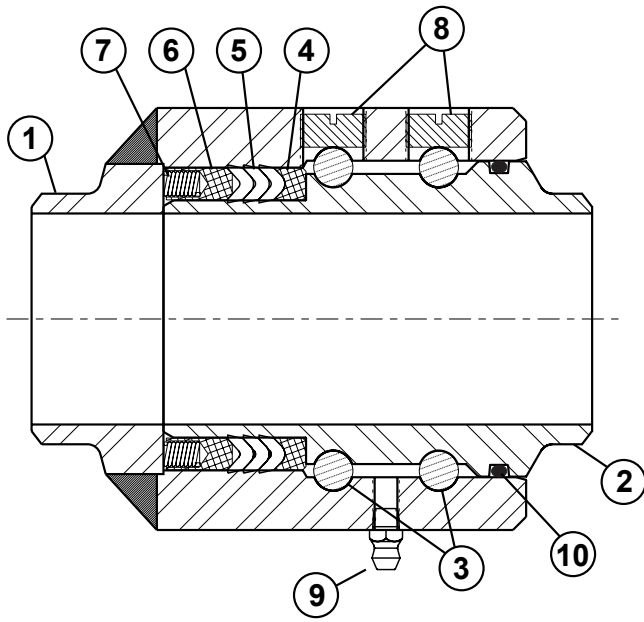

1. body
2. sleeve
3. ball bearings
4. seal retainer
5. V-ring (pressure) seal
6. spring retainer
7. spring
8. ball retainer screw
9. grease fitting
10. O-ring (dust) seal

weld end shown

Other available end configurations:

- Male NPT thread
- 300# ASA flange
- Tank car thread with gasket
- TTMA tank truck flange
- British pipe thread

Special Options

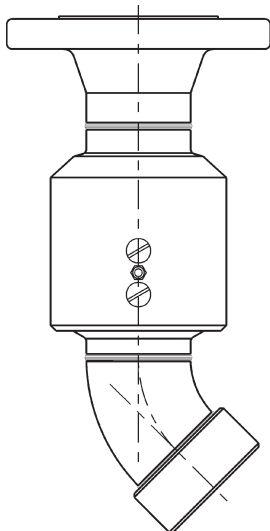

45° Swivel assembly
(style 30 shown)

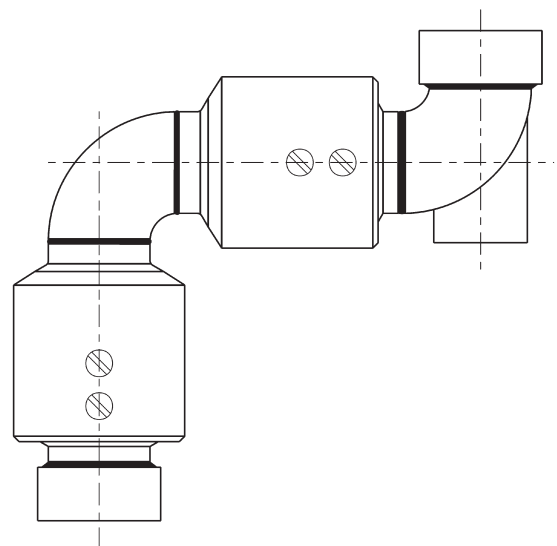

Swivel assembly with counterweight lug
(style 50 shown)

Typical V-Ring Swivel Applications

Loading Arm

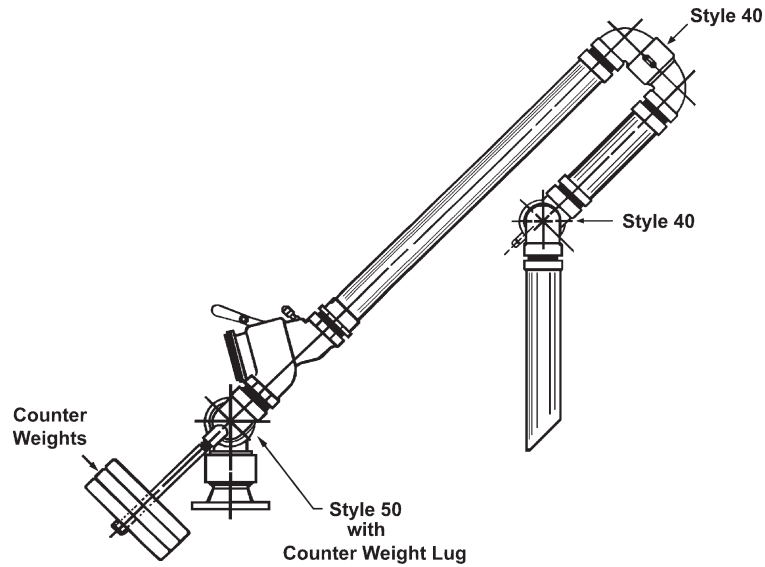

Floating Roof Drain

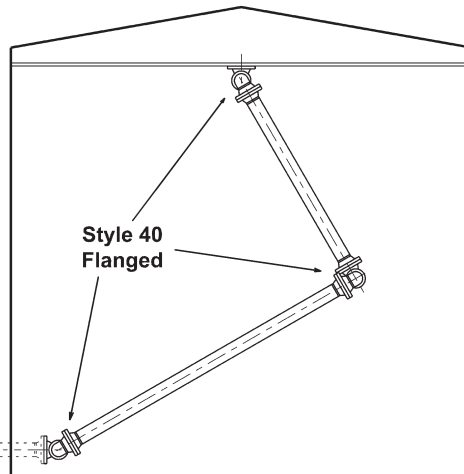

Floating Suction

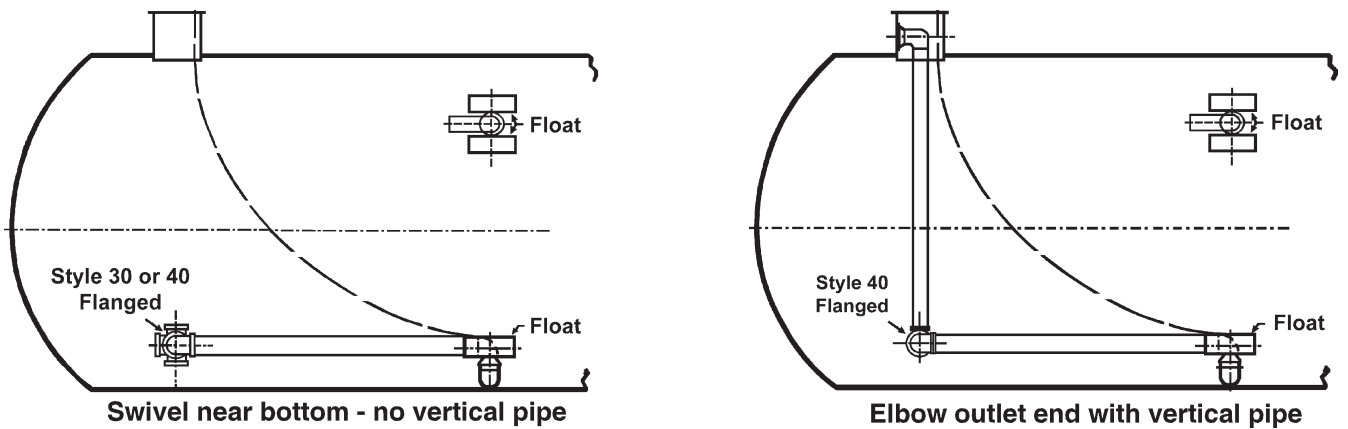

V-Ring Swivel Seal Replacement Procedure

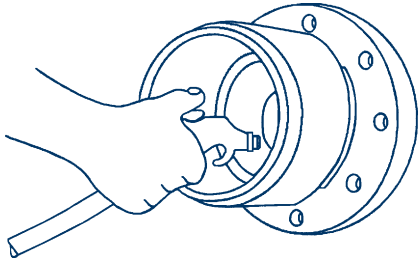

1 Remove the ball retainer screws. Add a sufficient amount of solvent into each raceway to flush out the lubricant. Rotate the sleeve, catching the balls as they fall out. When all the balls have been removed, the body and sleeve can be separated. Discard old seals. Thoroughly clean the body, sleeve retainer, spring retainer and springs. *

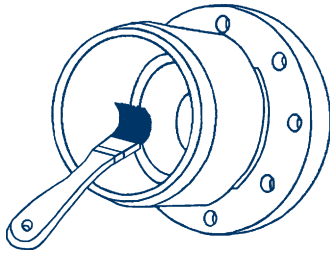

2 Lubricate the body unit with a Moly lubricant or equivalent.

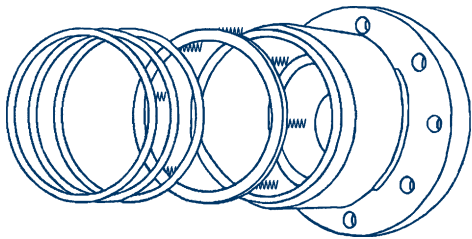

3 Place the assembled spring retainer unit (spring end first) into the body. Place the set of V rings onto the spring retainer. Be sure V rings are installed with the sealing lips facing toward the retainer. Lubricate the body and seals with a Moly lubricant or equivalent.

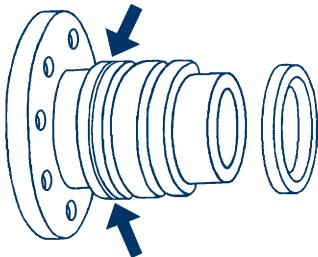

4 Set the dust seal into O ring groove on the sleeve. Place the seal retainer on the sleeve with the grooved end facing the V rings. Lubricate the sleeve with grease.

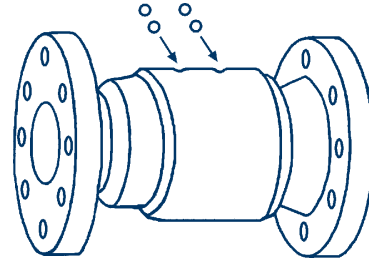

5 Insert sleeve into body, compressing swivel joint together until ball races of body and sleeve are in alignment (do not rotate either unit while compressing). Care should be taken to avoid pinching or scoring of V rings. Drop balls into raceway holes, rotating the sleeve slowly as you load. To make space for all the balls, insert a screw driver into the raceway while continuing to rotate the sleeve in one direction (be careful not to damage the threads). This will cause the balls to jam up, making room for the remaining balls. Now reverse the rotation of the sleeve and insert the remaining balls.

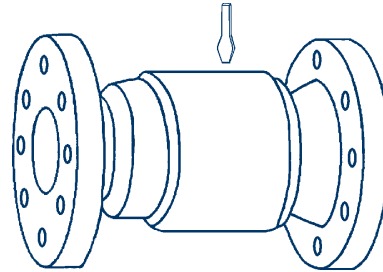

6 Reinstall ball retainer screws until tight. If this interferes with the smooth rotation of the ball bearings, then back off 1/8 - 1/4 turn. A thread locking sealant is recommended to prevent screws from backing off. After pressure testing, the unit is ready for installation.

* The last coil of the springs has been upset (OD slightly larger). When upset end is inserted into the holes provided in the spring retainer, the springs remain secure.



Caution:

Body and sleeve are matched during manufacturing. Do not mix components with other units.

Optional Seals for V-Ring Swivels

V-Ring - Pressure Seals

- V-Ring pressure seal material: FKM, PTFE (SS), PTFE (CS and AL) which includes changing to PTFE retainers, EPR and Buna-N, Buna-N is standard.
- V-Ring pressure seals are available in 2", 3", 4", 6" and 8"

O-Ring - Dust Seals

- Dust seal material: FKM, EPR and Buna-N, Buna-N is standard.
- O-ring dust seals are available in 2", 3", 4", 6" and 8"
- Carbon steel V-ring swivels come standard with aluminum retainers. These must be compatible with the material flowing through the swivel. PTFE retainers are available.

Rebuild Kits for V-Ring Swivels

V-ring swivel rebuild kit - each kit contains 3 V-rings in the material indicated, 1 Buna-N dust seal, 2 ball retainer screws, 1 grease plug and 10 ball bearings. The spring retainer and seal retainer *are not included* in the V-ring swivel rebuild kits.

Size	Buna	FKM	PTFE	EPR
2"	2RKVBU	2RKVVI	2RKVTF	2RKVEP
3"	3RKVBU	3RKVVI	3RKVTF	3RKVEP
4"	4RKVBU	4RKVVI	4RKVTF	4RKVEP
6"	6RKVBU	6RKVVI	6RKVTF	6RKVEP
8"	8RKVBU	8RKVVI	8RKVTF	8RKVEP

Note: All rebuild kits are per plane of rotation

Optional Ball Bearings for V-Ring Swivels

- Material: 440 stainless steel or 316 stainless steel
- Ball bearings are available in 2", 3", 4", 6" and 8"

Replacement Ball Bearings for V-Ring Swivels

Size	Quantity Per Plane of Rotation	Carbon Steel (standard)	440 Stainless Steel	316 Stainless Steel
		Part #	Part #	Part #
2"	50	38CSBA	38SSBA	38SSBA-316
3"	62	38CSBA	38SSBA	38SSBA-316
4"	84	38CSBA	38SSBA	38SSBA-316
6"	96	12CSBA	12SSBA	12SSBA-316
8"	84	34CSBA	34SSBA	34SSBA-316

Single Plane V-Ring Style 20 Weld end x Weld end

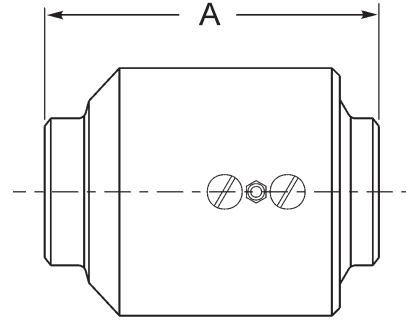

Size	Part #	Material	Weight (lbs)	Dimensions (inches) A
2"	220WXW	CS - carbon steel	9.2	5-5/16"
		SS - stainless steel	9.2	
3"	320WXW	CS - carbon steel	12.9	5-3/4"
		SS - stainless steel	13.1	
4"	420WXW	CS - carbon steel	24.4	7"
		SS - stainless steel	25.1	
6"	620WXW	CS - carbon steel	54.5	8-3/8"
		SS - stainless steel	56.5	
		AL - aluminum	21.6	
8"	820WXW	CS - carbon steel	78.3	8-5/8"
		SS - stainless steel	92.3	
		AL - aluminum	35.3	



Caution:

Weld end swivel joints should be completely disassembled prior to welding, so as not to damage the seals. Care should be taken to avoid distortion of seal and ball race diameters.

Swivels are shipped standard with the following components:

- *Buna-N* for pressure seals and dust seals
- *Carbon steel* for ball bearings
- *Aluminum* for retainers in carbon steel swivels
- *PTFE* for retainers in stainless steel swivels

Single Plane V-Ring Style 20 Female NPT x Female NPT

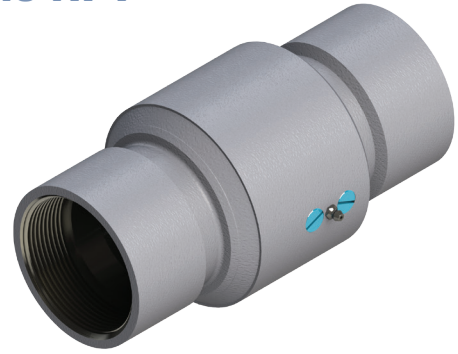
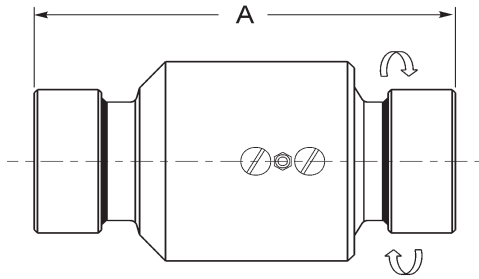

Size	Part #	Material	Weight (lbs)	Dimensions (inches) A
2"	220FXF	CS - carbon steel	12.7	8-11/16"
		SS - stainless steel	12.2	
3"	320FXF	CS - carbon steel	17.0	10"
		SS - stainless steel	18.4	
4"	420FXF	CS - carbon steel	36.7	11-3/4"
		SS - stainless steel	37.7	
6"	620FXF	CS - carbon steel	67.5	12-1/8"
		SS - stainless steel	69.5	
		AL - aluminum	25.8	
8"	820FXF	CS - carbon steel	---	12-7/8"
		SS - stainless steel	---	
		AL - aluminum	---	

150# ASA Flange x 150# ASA Flange

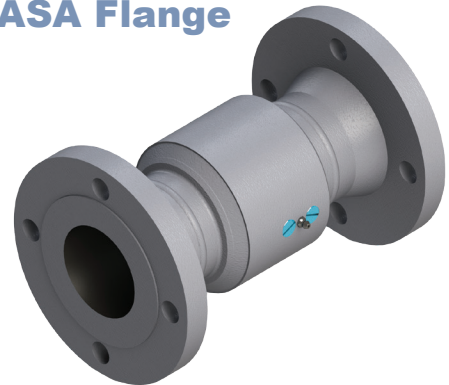
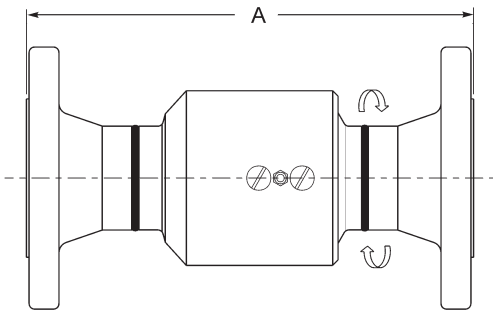

Size	Part #	Material	Weight (lbs)	Dimensions (inches) A
2"	220FGXFG	CS - carbon steel	21.7	10-5/16"
		SS - stainless steel	21.1	
3"	320FGXFG	CS - carbon steel	36.0	11-1/4"
		SS - stainless steel	35.3	
4"	420FGXFG	CS - carbon steel	57.4	13"
		SS - stainless steel	58.1	
6"	620FGXFG	CS - carbon steel	104.2	15-3/8"
		SS - stainless steel	106.2	
		AL - aluminum	39.0	
8"	820FGXFG	CS - carbon steel	162.3	16-5/8"
		SS - stainless steel	170.3	
		AL - aluminum	61.0	

Single Plane V-Ring Style 30 Female NPT x Female NPT

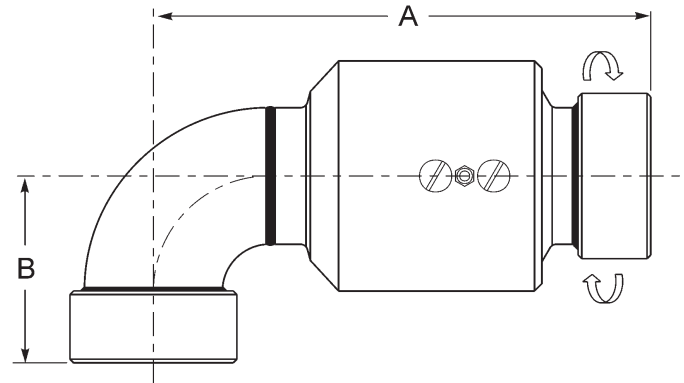

Size	Part #	Material	Weight (lbs)	Dimensions (inches)	
				A	B
2"	230FXF	CS - carbon steel	12.1	9"	3-11/16"
		SS - stainless steel	12.1		
3"	330FXF	CS - carbon steel	20.6	10-7/8"	5-1/8"
		SS - stainless steel	21.3		
4"	430FXF	CS - carbon steel	42.4	13-3/8"	6-3/8"
		SS - stainless steel	44.4		
6"	630FXF	CS - carbon steel	84.3	16-1/4"	7-7/8"
		SS - stainless steel	84.2		
		AL - aluminum	31.5		

Swivels are shipped standard with the following components:

- *Buna-N* for pressure seals and dust seals
- *Carbon steel* for ball bearings
- *Aluminum* for retainers in carbon steel swivels
- *PTFE* for retainers in stainless steel swivels

Single Plane V-Ring Style 30 10# ASA Flange x 150# ASA Flange

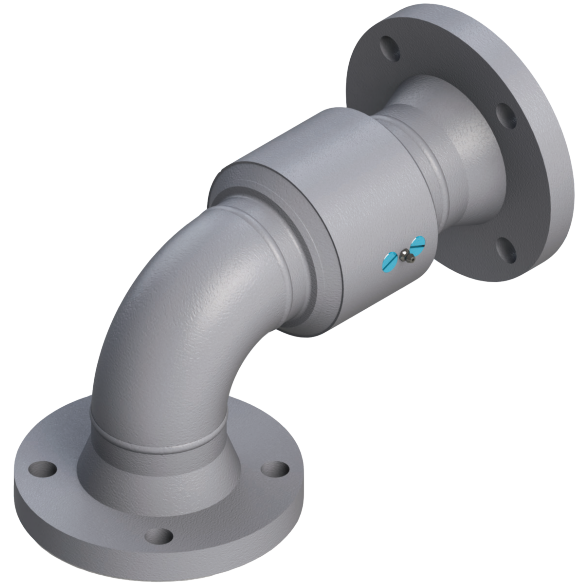
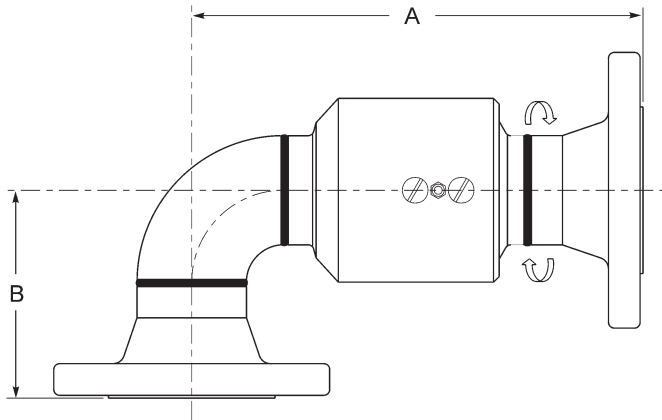

Size	Part #	Material	Weight (lbs)	Dimensions (inches)	
				A	B
2"	230FGXFG	CS - carbon steel	22.7	9-13/16"	4-1/2"
		SS - stainless steel	22.1		
3"	330FGXFG	CS - carbon steel	39.4	11-1/2"	5-3/4"
		SS - stainless steel	38.2		
4"	430FGXFG	CS - carbon steel	63.6	14"	7"
		SS - stainless steel	64.8		
6"	630FGXFG	CS - carbon steel	121.0	17-7/8"	9-1/2"
		SS - stainless steel	120.9		
		AL - aluminum	44.7		
8"	830FGXFG	CS - carbon steel	196.3	20-5/8"	12"
		SS - stainless steel	207.9		
		AL - aluminum	76.6		

Swivels are shipped standard with the following components:

- *Buna-N* for pressure seals and dust seals
- *Carbon steel* for ball bearings
- *Aluminum* for retainers in carbon steel swivels
- *PTFE* for retainers in stainless steel swivels

Single Plane V-Ring Style 40 Female NPT x Female NPT

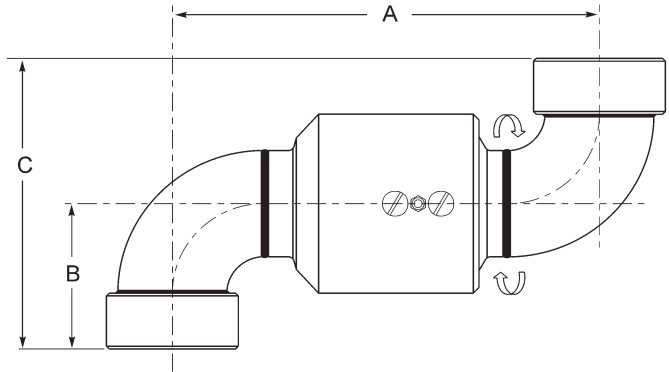

Size	Part #	Material	Weight (lbs)	Dimensions (inches)		
				A	B	C
2"	240FXF	CS - carbon steel	13.1	9-5/16"	3-11/16"	7-3/8"
		SS - stainless steel	13.1			
3"	340FXF	CS - carbon steel	24.0	11-3/4"	5-1/8"	10-1/4"
		SS - stainless steel	24.2			
4"	440FXF	CS - carbon steel	48.6	15"	6-3/8"	12-3/4"
		SS - stainless steel	51.1			
6"	640FXF	CS - carbon steel	101.1	20-3/8"	7-7/8"	15-3/4"
		SS - stainless steel	98.9			
		AL - aluminum	39.0			

Swivels are shipped standard with the following components:

- *Buna-N* for pressure seals and dust seals
- *Carbon steel* for ball bearings
- *Aluminum* for retainers in carbon steel swivels
- *PTFE* for retainers in stainless steel swivels

Single Plane V-Ring Style 40 150# ASA Flange x 150# ASA Flange

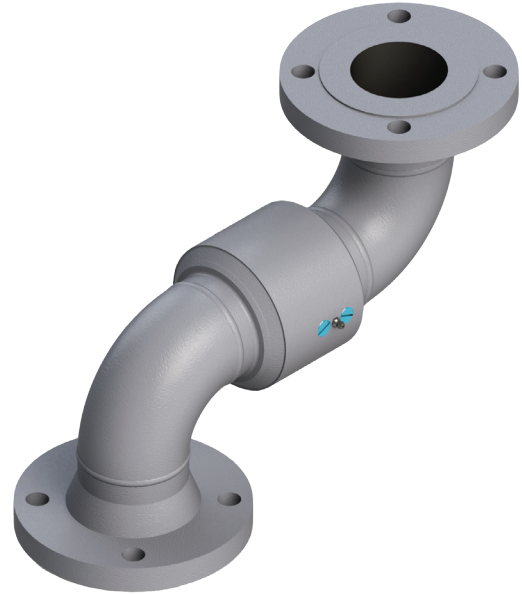
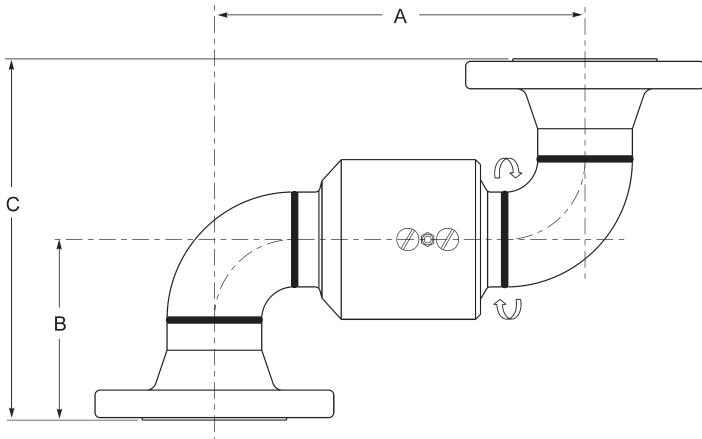

Size	Part #	Material	Weight (lbs)	Dimensions (inches)		
				A	B	C
2"	240FGXFG	CS - carbon steel	23.7	9-5/16"	4-1/2"	9"
		SS - stainless steel	23.1			
3"	340FGXFG	CS - carbon steel	42.8	11-3/4"	5-3/4"	11-1/2"
		SS - stainless steel	41.1			
4"	440FGXFG	CS - carbon steel	69.8	15"	7"	14"
		SS - stainless steel	71.5			
6"	640FGXFG	CS - carbon steel	137.8	20-3/8"	9-1/2"	19"
		SS - stainless steel	135.6			
		AL - aluminum	52.2			
8"	840FGXFG	CS - carbon steel	230.3	24-5/8"	12"	24"
		SS - stainless steel	245.5			
		AL - aluminum	92.2			

Swivels are shipped standard with the following components:

- *Buna-N* for pressure seals and dust seals
- *Carbon steel* for ball bearings
- *Aluminum* for retainers in carbon steel swivels
- *PTFE* for retainers in stainless steel swivels

Double Plane V-Ring Style 50 Female NPT x Female NPT

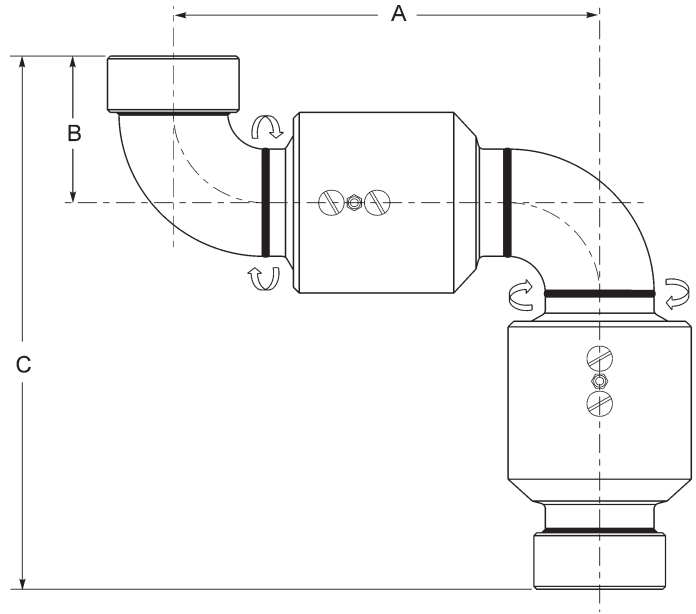

Size	Part #	Material	Weight (lbs)	Dimensions (inches)		
				A	B	C
2"	250FXF	CS - carbon steel	22.8	9-5/16"	3-11/16"	12-11/16"
		SS - stainless steel	23.3			
3"	350FXF	CS - carbon steel	36.9	11-3/4"	5-1/8"	16"
		SS - stainless steel	37.3			
4"	450FXF	CS - carbon steel	73.0	15"	6-3/8"	19-3/4"
		SS - stainless steel	76.2			
6"	650FXF	CS - carbon steel	155.6	20-3/8"	7-7/8"	24-1/8"
		SS - stainless steel	---			
		AL - aluminum	60.6			

Swivels are shipped standard with the following components:

- *Buna-N* for pressure seals and dust seals
- *Carbon steel* for ball bearings
- *Aluminum* for retainers in carbon steel swivels
- *PTFE* for retainers in stainless steel swivels

Double Plane V-Ring Style 50 150# ASA Flange x 150# ASA Flange

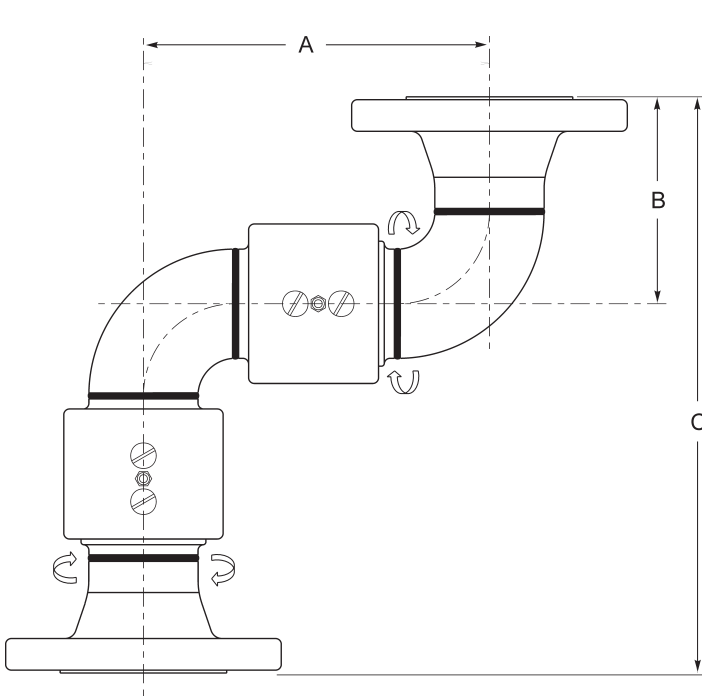

Size	Part #	Material	Weight (lbs)	Dimensions (inches)		
				A	B	C
2"	250FGXFG	CS - carbon steel	32.8	9-5/16"	4-1/2"	14-5/16"
		SS - stainless steel	32.2			
3"	350FGXFG	CS - carbon steel	55.7	11-3/4"	5-3/4"	17-1/4"
		SS - stainless steel	54.3			
4"	450FGXFG	CS - carbon steel	94.2	15"	7"	21"
		SS - stainless steel	96.6			
6"	650FGXFG	CS - carbon steel	192.3	20-3/8"	9-1/2"	27-3/8"
		SS - stainless steel	192.1			
		AL - aluminum	73.8			
8"	850FGXFG	CS - carbon steel	308.6	24-5/8"	12"	32-5/8"
		SS - stainless steel	337.8			
		AL - aluminum	127.5			

Swivels are shipped standard with the following components:

- *Buna-N* for pressure seals and dust seals
- *Carbon steel* for ball bearings
- *Aluminum* for retainers in carbon steel swivels
- *PTFE* for retainers in stainless steel swivels

Double Plane V-Ring Style 60 Female NPT x Female NPT

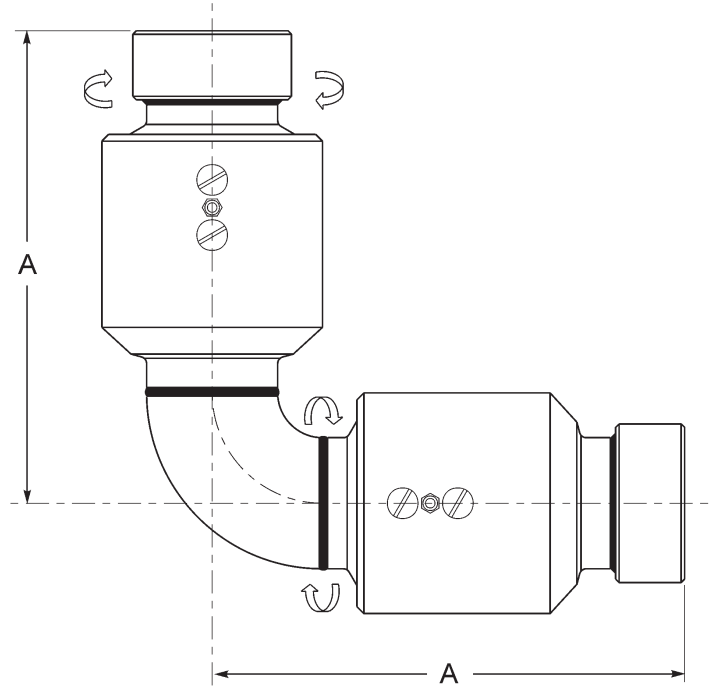
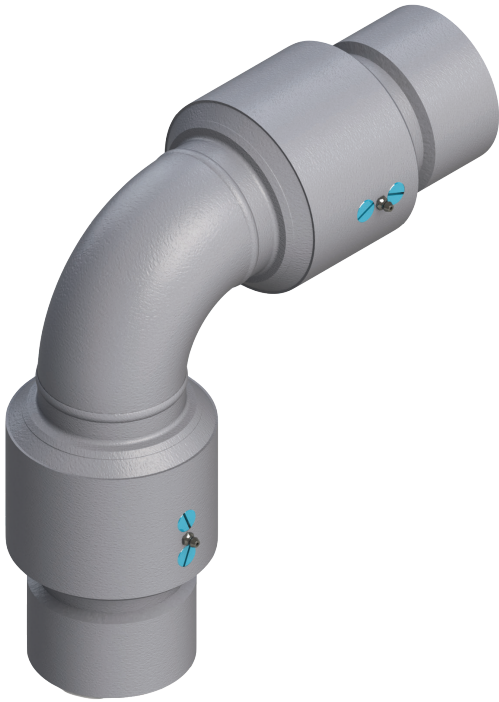

Size	Part #	Material	Weight (lbs)	Dimensions (inches) A
2"	260FXF	CS - carbon steel	21.40	9"
		SS - stainless steel	21.50	
3"	360FXF	CS - carbon steel	34.30	10-7/8"
		SS - stainless steel	34.30	
4"	460FXF	CS - carbon steel	72.00	13-3/8"
		SS - stainless steel	72.00	
6"	660FXF	CS - carbon steel	118.00	16-1/4"
		SS - stainless steel	---	
		AL - aluminum	---	

Swivels are shipped standard with the following components:

- *Buna-N* for pressure seals and dust seals
- *Carbon steel* for ball bearings
- *Aluminum* for retainers in carbon steel swivels
- *PTFE* for retainers in stainless steel swivels

Double Plane V-Ring Style 60 150# ASA Flange x 150# ASA Flange

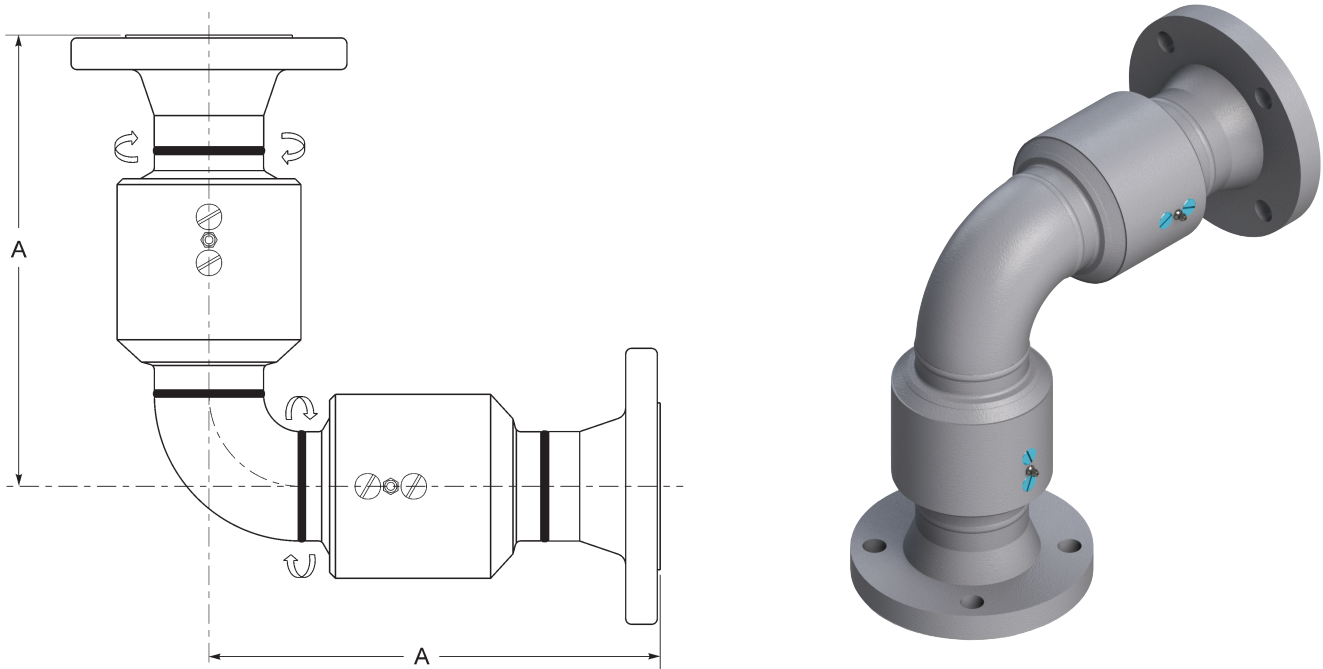

Size	Part #	Material	Weight (lbs)	Dimensions (inches) A
2"	260FXF	CS - carbon steel	42.00	9-13/16"
		SS - stainless steel	42.00	
3"	360FXF	CS - carbon steel	83.00	11-1/2"
		SS - stainless steel	83.00	
4"	460FXF	CS - carbon steel	106.00	14"
		SS - stainless steel	106.00	
6"	660FXF	CS - carbon steel	172.00	17-7/8"
		SS - stainless steel	172.00	
		AL - aluminum	---	
8"	860FGXFG	CS - carbon steel	312.00	20-5/8"
		SS - stainless steel	312.00	
		AL - aluminum	---	

Swivels are shipped standard with the following components:

- *Buna-N* for pressure seals and dust seals
- *Carbon steel* for ball bearings
- *Aluminum* for retainers in carbon steel swivels
- *PTFE* for retainers in stainless steel swivels

Double Plane V-Ring Style 70 Female NPT x Female NPT

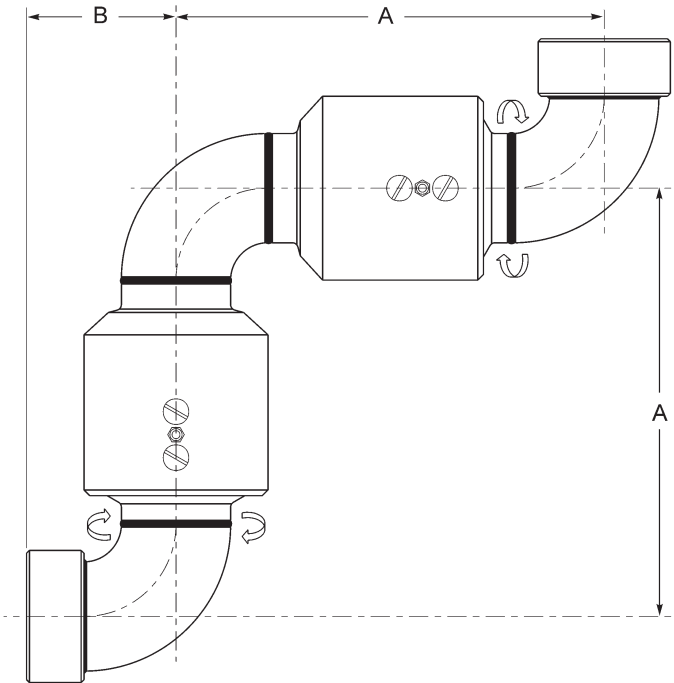
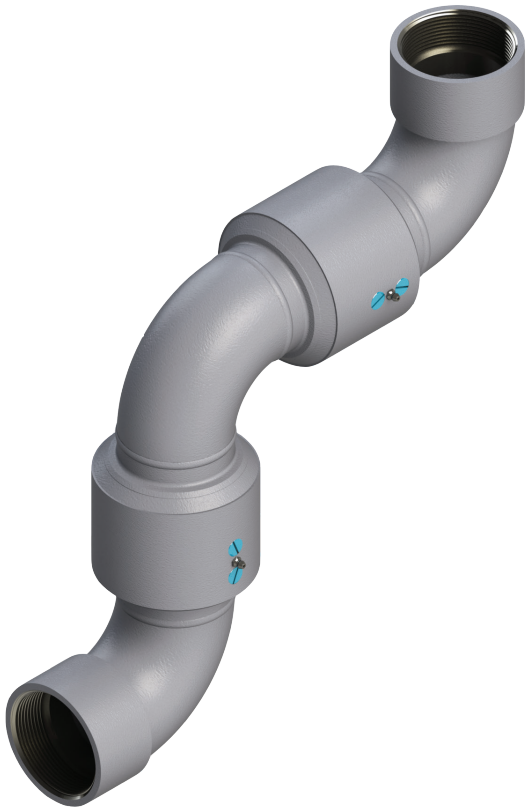

Size	Part #	Material	Weight (lbs)	Dimensions (inches)	
				A	B
2"	270FXF	CS - carbon steel	23.7	9-5/16"	3-11/16
		SS - stainless steel	24.35		
3"	370FXF	CS - carbon steel	40.3	11-3/4"	5-1/8"
		SS - stainless steel	40.2		
4"	470FXF	CS - carbon steel	79.2	15"	6-3/8"
		SS - stainless steel	82.9		
6"	670FXF	CS - carbon steel	172.4	20-3/8"	7-7/8"
		SS - stainless steel	---		
		AL - aluminum	---		

Swivels are shipped standard with the following components:

- *Buna N* for pressure seals and dust seals
- *Carbon steel* for ball bearings
- *Aluminum* for retainers in carbon steel swivels
- *PTFE* for retainers in stainless steel swivels

Double Plane V-Ring Style 70 150# ASA Flange x 150# ASA Flange

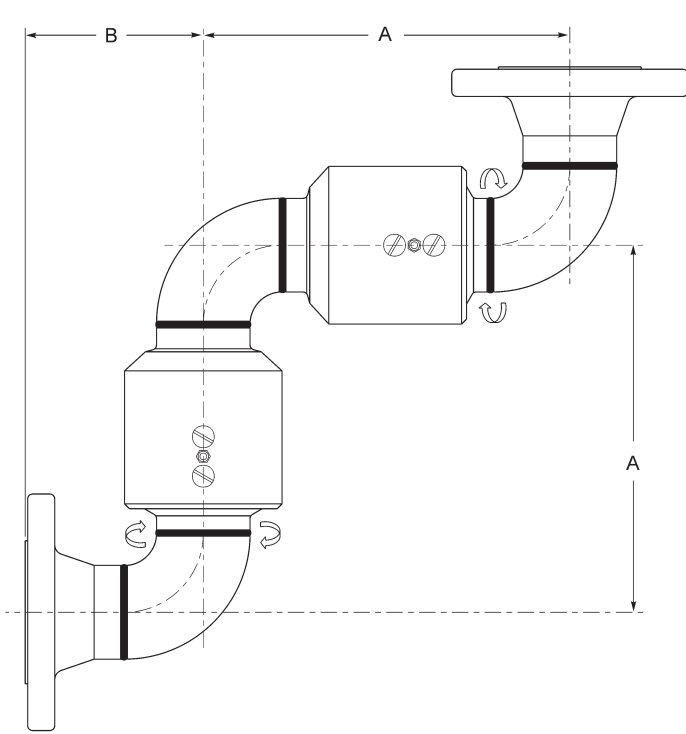

Size	Part #	Material	Weight (lbs)	Dimensions (inches)	
				A	B
2"	270FGXFG	CS - carbon steel	33.8	9-5/16"	4-1/2"
		SS - stainless steel	33.2		
3"	370FGXFG	CS - carbon steel	59.1	11-3/4"	5-3/4"
		SS - stainless steel	57.2		
4"	470FGXFG	CS - carbon steel	100.4	15"	7"
		SS - stainless steel	103.3		
6"	670FGXFG	CS - carbon steel	209.1	20-3/8"	9-1/2"
		SS - stainless steel	206.8		
		AL - aluminum	81.5		
8"	870FGXFG	CS - carbon steel	342.6	24-5/8"	12"
		SS - stainless steel	375.4		
		AL - aluminum	143.0		

Swivels are shipped standard with the following components:

- *Buna-N* for pressure seals and dust seals
- *Carbon steel* for ball bearings
- *Aluminum* for retainers in carbon steel swivels
- *PTFE* for retainers in stainless steel swivels

Triple Plane V-Ring Style 80 Female NPT x Female NPT

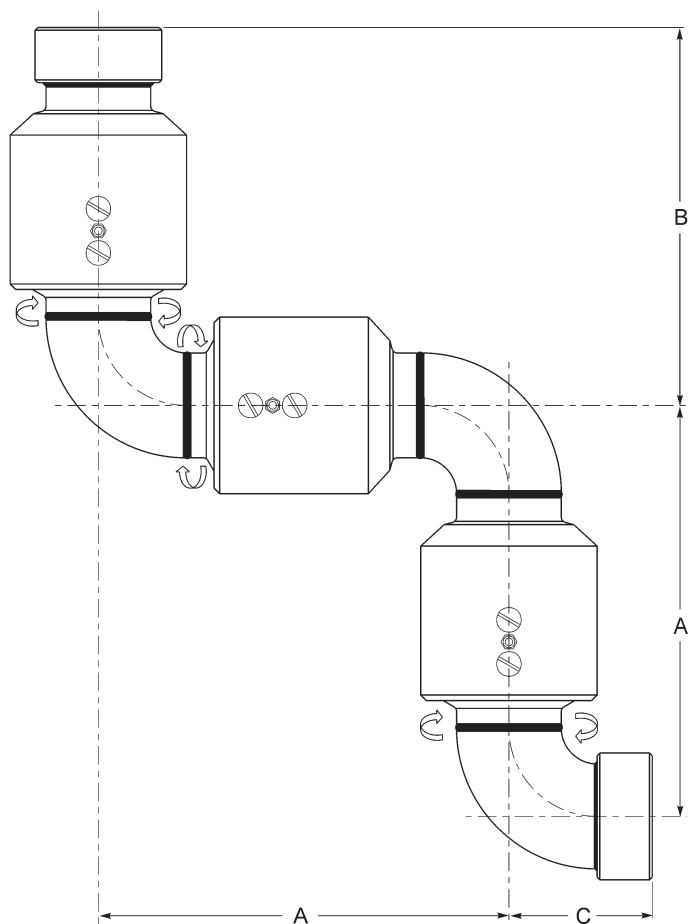

Size	Part #	Material	Weight (lbs)	Dimensions (inches)		
				A	B	C
2"	280FXF	CS - carbon steel	33.0	9-5/16"	9-9/16"	3-11/16"
		SS - stainless steel	33.5			
3"	380FXF	CS - carbon steel	53.2	11-3/4"	10-7/8"	5-1/8"
		SS - stainless steel	53.3			
4"	480FXF	CS - carbon steel	103.6	15"	13-3/8"	6-3/8"
		SS - stainless steel	108.0			
6"	680FXF	CS - carbon steel	226.9	20-3/8"	16-1/4"	7-7/8"
		SS - stainless steel	226.6			
		AL - aluminum	---			

Swivels are shipped standard with the following components:

- *Buna-N* for pressure seals and dust seals
- *Carbon steel* for ball bearings
- *Aluminum* for retainers in carbon steel swivels
- *PTFE* for retainers in stainless steel swivels

Triple Plane V-Ring Style 80 150# ASA Flange x 150# ASA Flange

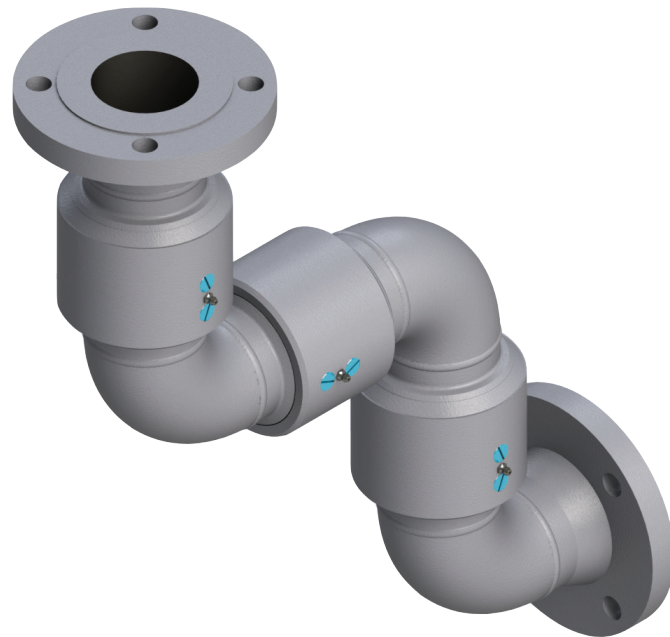
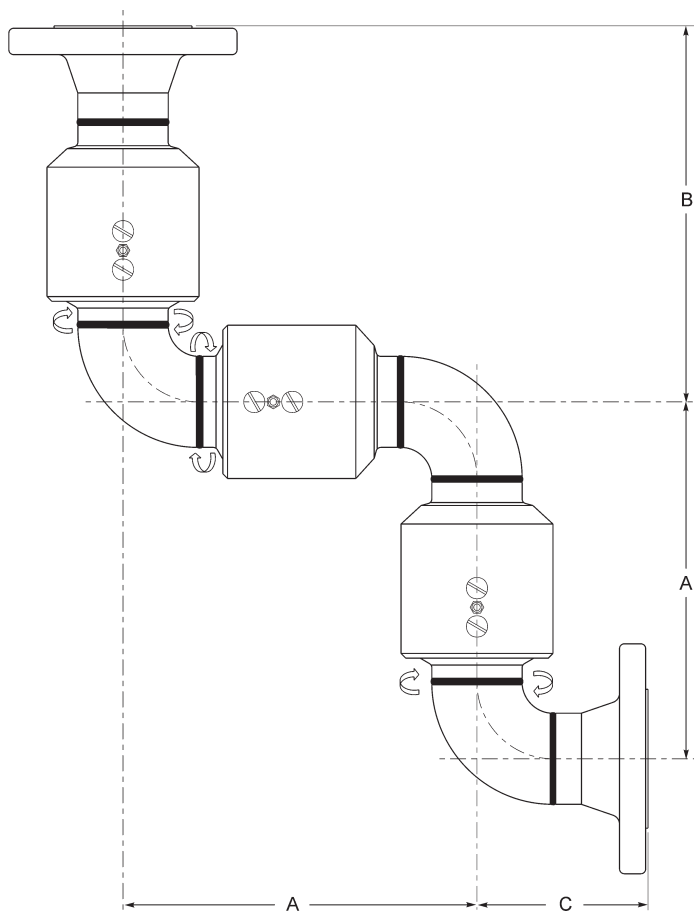

Size	Part #	Material	Weight (lbs)	Dimensions (inches)		
				A	B	C
2"	280FGXFG	CS - carbon steel	43.1	9-5/16"	9-13/16"	4-1/2"
		SS - stainless steel	42.4			
3"	380FGXFG	CS - carbon steel	72.0	11-3/4"	11-1/2"	5-3/4"
		SS - stainless steel	70.3			
4"	480FGXFG	CS - carbon steel	124.8	15"	14"	7"
		SS - stainless steel	128.4			
6"	680FGXFG	CS - carbon steel	263.6	20-3/8"	17-7/8"	9-1/2"
		SS - stainless steel	263.3			
		AL - aluminum	102.2			
8"	880FGXFG	CS - carbon steel	420.9	24-5/8"	20-5/8"	12"
		SS - stainless steel	467.6			
		AL - aluminum	178.0			

Swivels are shipped standard with the following components:

- *Buna-N* for pressure seals and dust seals
- *Carbon steel* for ball bearings
- *Aluminum* for retainers in carbon steel swivels
- *PTFE* for retainers in stainless steel swivels

Triple Plane V-Ring Style 10 Female NPT x Female NPT

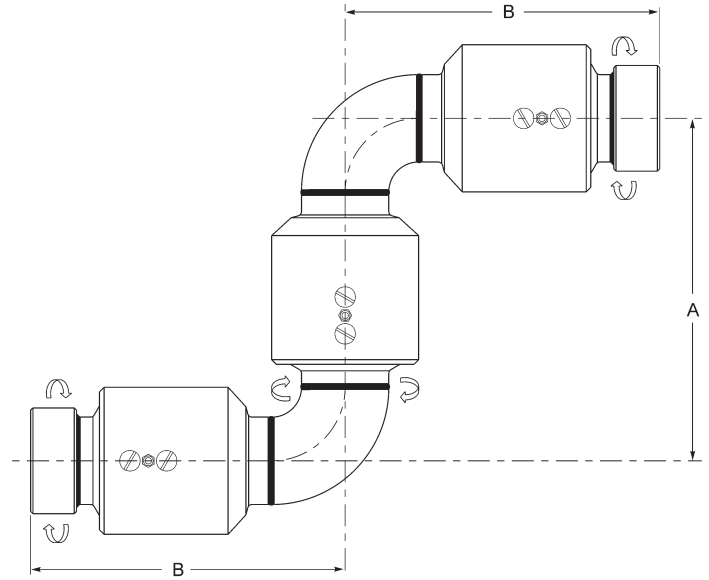
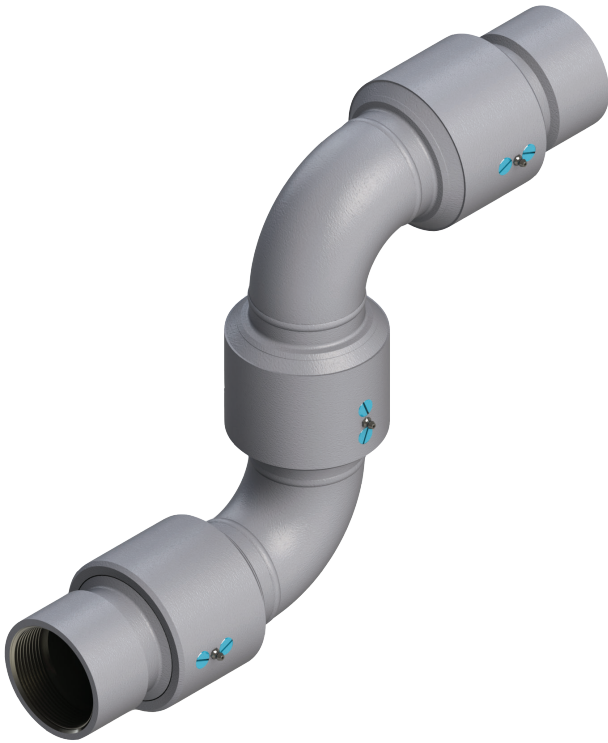

Size	Part #	Material	Weight (lbs)	Dimensions (inches)	
				A	B
2"	210FXF	CS - carbon steel	32.0	9-5/16"	9"
		SS - stainless steel	32.5		
3"	310FXF	CS - carbon steel	49.8	11-3/4"	10-7/8"
		SS - stainless steel	50.4		
4"	410FXF	CS - carbon steel	97.4	15"	13-3/8"
		SS - stainless steel	101.3		
6"	610FXF	CS - carbon steel	210.2	20-3/8"	16-1/4"
		SS - stainless steel	---		
		AL - aluminum	---		

Swivels are shipped standard with the following components:

- *Buna-N* for pressure seals and dust seals
- *Carbon steel* for ball bearings
- *Aluminum* for retainers in carbon steel swivels
- *PTFE* for retainers in stainless steel swivels

Triple Plane V-Ring Style 10 150# ASA Flange x 150# ASA Flange

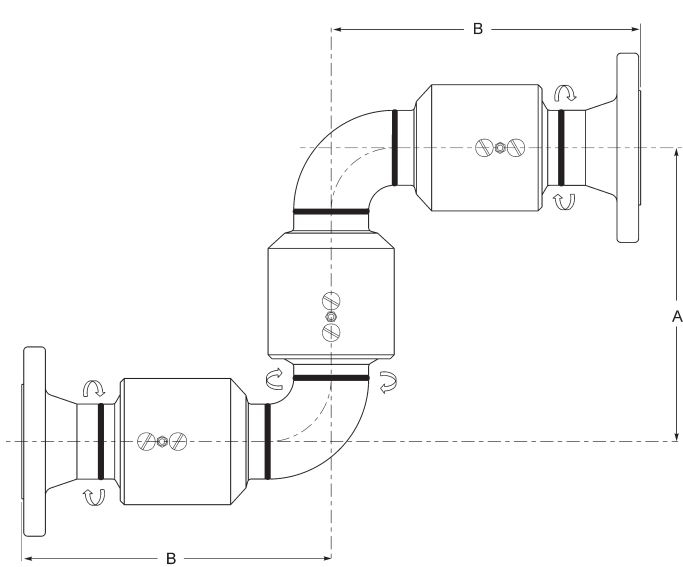

Size	Part #	Material	Weight (lbs)	Dimensions (inches)	
				A	B
2"	210FGXFG	CS - carbon steel	42.1	9-5/16"	9-13/16"
		SS - stainless steel	41.4		
3"	310FGXFG	CS - carbon steel	68.6	11-3/4"	11-1/2"
		SS - stainless steel	67.4		
4"	410FGXFG	CS - carbon steel	118.6	15"	14"
		SS - stainless steel	121.7		
6"	610FGXFG	CS - carbon steel	222.1	20-3/8"	17-7/8"
		SS - stainless steel	233.9		
		AL - aluminum	97.2		
8"	810FGXFG	CS - carbon steel	386.9	24-5/8"	20-5/8"
		SS - stainless steel	430.1		
		AL - aluminum	162.8		

Swivels are shipped standard with the following components:

- *Buna-N* for pressure seals and dust seals
- *Carbon steel* for ball bearings
- *Aluminum* for retainers in carbon steel swivels
- *PTFE* for retainers in stainless steel swivels

O-Ring Parts Identification List

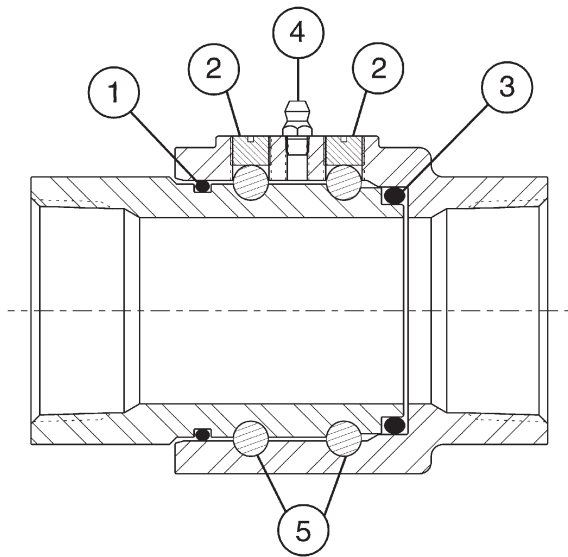

- 1) O-ring (dust) seal
- 2) ball retainer screw
- 3) O-ring (pressure) seal
- 4) grease fitting
- 5) ball bearings

female NPT shown

Other available end configurations:

- Tank car thread with gasket
- TTMA tank truck flange

Spring-Loaded PTFE Pressure Seal for O-Ring Swivels

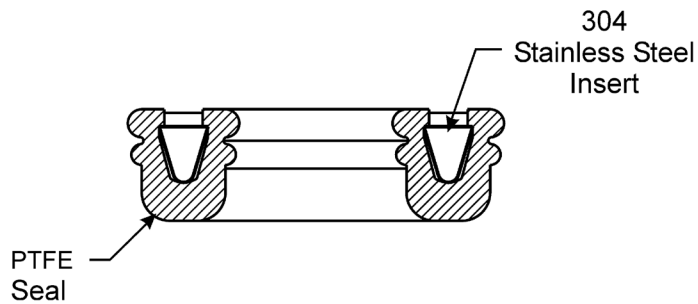

Cross Sectional View of Seal
(for use in sizes 1" - 3")

Special Options for O-Ring Swivels

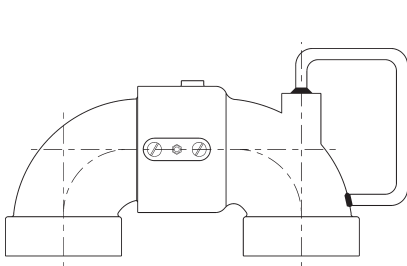

Swivel with Handle
(style 40 shown)

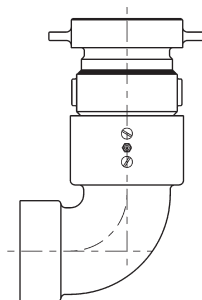

Tank Car Swivel
(style 30 shown)

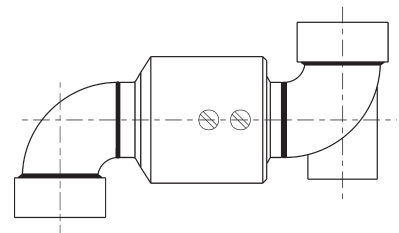

Swivel Assembly with
Counterweight Lug
(style 40 shown)

Typical Applications for O-Ring Swivels

Loading Arm

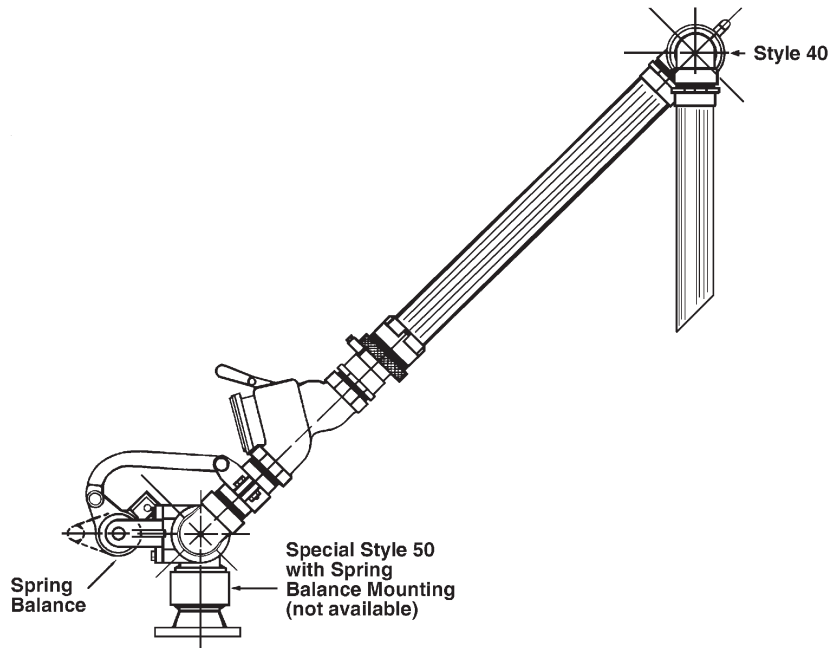

Hose Loaders

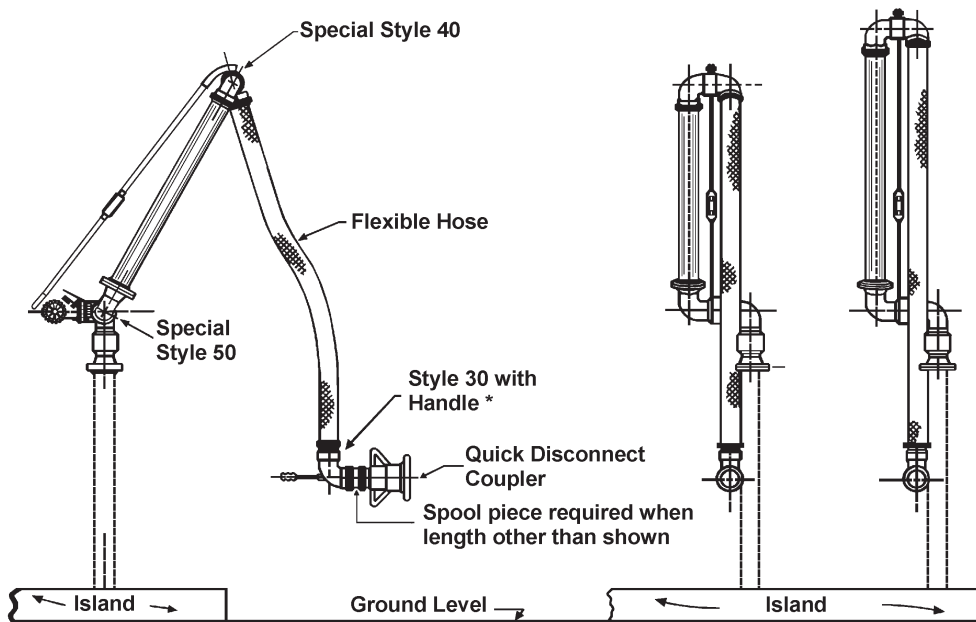

Note: style 60 may also be used in this application

O-Ring Swivel Seal Replacement Procedure

Note: Instructions not for assembly with spring-loaded PTFE pressure seal. Consult the factory.

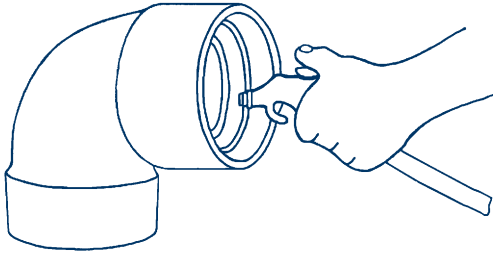

1 Remove the ball retainer screws. Add a sufficient amount of solvent into each raceway to flush out the lubricant. Rotate the sleeve, catching the balls as they fall out. When all the balls have been removed, the body and sleeve can be separated. Discard old seals. Thoroughly clean the body and sleeve.

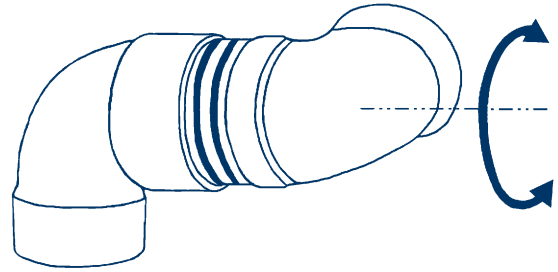

4 Insert the sleeve into the body, slowly rotate the sleeve while inserting into the body.

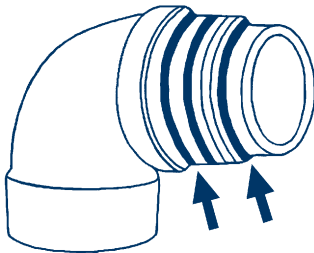

2 Install the new O rings on the sleeve, dust seal to the rear, product (pressure) seal up front.

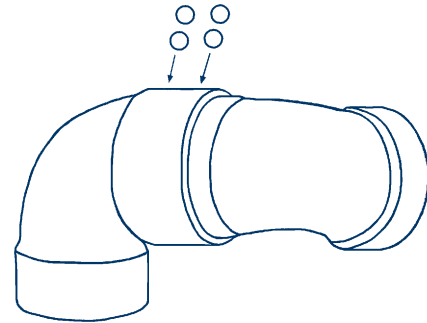

5 When the sleeve is fully inserted, feed the ball bearings into the raceways while rotating the sleeve. To make space for all the balls, insert a screw driver into the raceway, while continuing to rotate the sleeve in one direction (be careful not to damage the threads). This will cause the balls to jam up, making room for the remaining balls. Now reverse rotation of sleeve and insert the remaining balls.

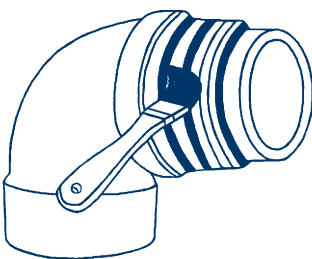

3 Lubricate the body and the sleeve with grease.

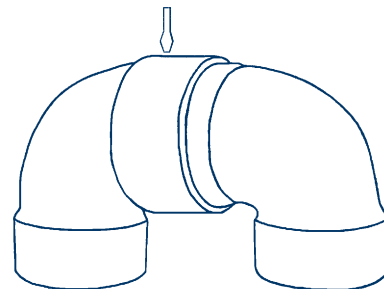

6 Reinstall ball retainer screws until tight. If this interferes with the smooth rotation of the ball bearings, then back off 1/8 - 1/4 turn. A thread locking sealant is recommended to prevent screws from backing off. After pressure testing, the unit is ready for installation.



Caution:

Body and sleeve are matched during manufacturing. Do not mix components with other units.

Optional Seals for O-Ring Swivels

O-Ring - Pressure Seals

- O-ring pressure seal material: FKM, spring-loaded PTFE, EPR, food grade Buna and Buna-N, Buna-N is standard.
- O-ring pressure seals are available in 1", 1¼" and 1½", 2", 3" and 4"

O-Ring - Dust Seals

- Dust seal material: FKM, EPR and Buna-N, Buna-N is standard.
- O-ring dust seals are available in 1", 1¼", 1½", 2", 3" and 4".

Note: When a change of seals is ordered, only the pressure seal is changed unless specifically requested by the customer.

Rebuild Kits for O-Ring Swivels

O-ring swivel rebuild kit - each kit contains 1 O-ring (pressure seal) in the material indicated, 1 Buna-N dust seal, 2 ball retainer screws, 1 grease plug and 10 ball bearings.

Size	Buna	FKM	PTFE	EPR
1"	1RKOBU	1RKОВI	1RKOTF	---
1¼ and 1½"	150RKOBU	150RKОВI	150RKOTF	150RKOEP
2"	2RKOBU	2RKОВI	2RKOTF	2RKOEP
3"	3RKOBU	3RKОВI	3RKOTF	3RKOEP
4"	4RKOBU	4RKОВI	---	4RKOEP

Note: All rebuild kits are per plane of rotation

Optional Ball Bearings for O-Ring Swivels

- Material: 440 stainless steel or 316 stainless steel
- Ball bearings are offered in 1", 1¼", 1½", 2", 3" and 4"

Replacement Ball Bearings for O-Ring Swivels

Size	Quantity Per Plane of Rotation	Carbon Steel (standard)	440 Stainless Steel	316 Stainless Steel
		Part #	Part #	Part #
2"	40	14CSBA	14SSBA	14SSBA-316
3"	56	14CSBA	14SSBA	14SSBA-316
4"	46	38CSBA	38SSBA	38SSBA-316
6"	60	38CSBA	38SSBA	38SSBA-316
8"	80	38CSBA	38SSBA	38SSBA-316

Single Plane O-Ring Style 20 Female NPT x Female NPT

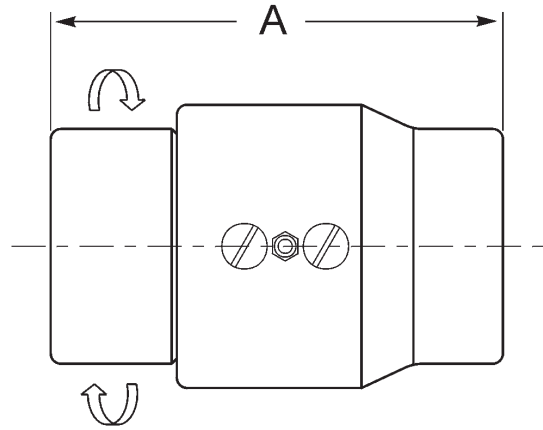

Size	Part #	Material	Weight (lbs)	Dimensions (inches) A
1"	120FXF	OC - carbon steel	2.80	3-15/16"
		OS - stainless steel	2.50	
		AL - aluminum	1.10	
1¼"	12520FXF	AL - aluminum	1.40	3-31/32"
1½"	15020FXF	OC - carbon steel	3.55	4"
		OS - stainless steel	3.55	
		AL - aluminum	1.40	
		BR - brass	4.30	
		MI - malleable iron	3.80	
2"	220FXF	OC - carbon steel	6.30	5-9/16"
		OS - stainless steel	6.80	
		AL - aluminum	3.50	
		BR - brass	8.50	
		MI - malleable iron	7.50	
3"	320FXF	OC - carbon steel	8.60	5-7/8"
		OS - stainless steel	9.00	
		AL - aluminum	4.00	5-29/32"
		BR - brass	11.10	
		MI - malleable iron	9.70	
4"	420FXF	AL - aluminum	7.30	7-5/8"

Swivels are shipped standard with the following components:

- *Buna-N* for pressure seals and dust seals
- *Carbon steel* for ball bearings

Single Plane O-Ring Style 20 150# ASA Flange x 150# ASA Flange

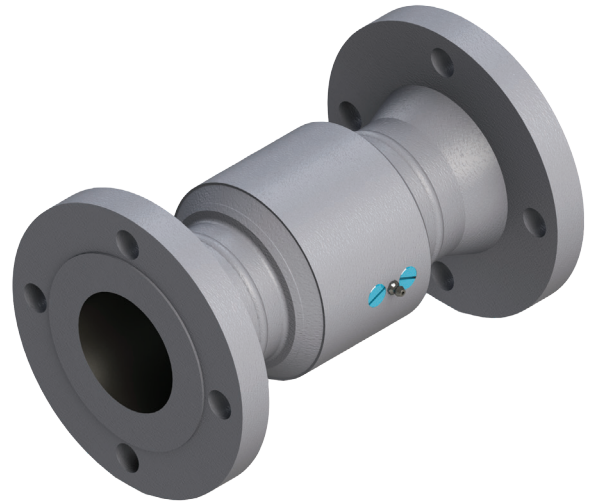
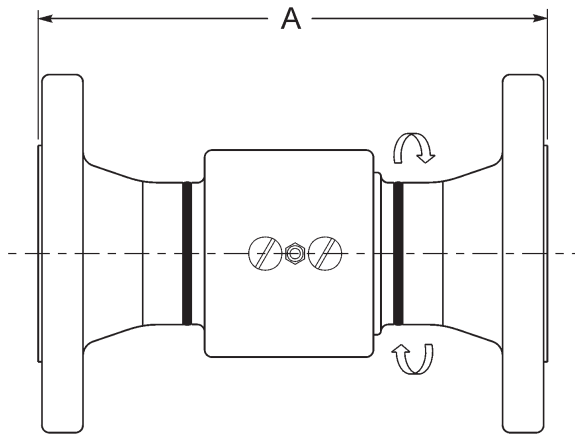

Size	Part #	Material	Weight (lbs)	Dimensions (inches) A
1"	120FGXFG	OC - carbon steel	7.80	7-9/32"
1½"	15020FGXFG	OC - carbon steel	11.60	8-1/16"
		OS - stainless steel	11.60	8-11/16"
		AL - aluminum	---	8-11/16"
2"	220FGXFG	OC - carbon steel	16.60	8-17/32"
		OS - stainless steel	16.60	10-3/8"
		AL - aluminum	7.50	10-3/8"
3"	320FGXFG	OC - carbon steel	30.60	9-5/8"
		OS - stainless steel	30.60	11-5/32"
		AL - aluminum	10.00	11-5/32"
4"	420FGXFG	AL - aluminum	13.00	13-5/16"

Single Plane O-Ring Style 30 Female NPT x Female NPT

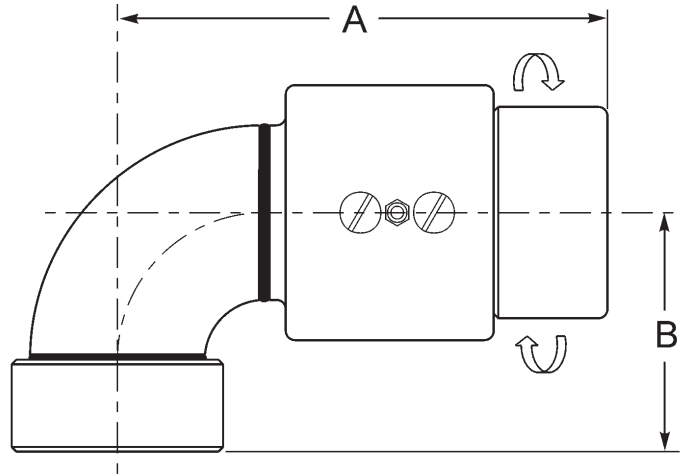

Size	Part #	Material	Weight (lbs)	Dimensions (inches)	
				A	B
1"	130FXF	OC - carbon steel	3.6	4-13/32"	2-3/16"
		OS - stainless steel	3.0	5-29/32"	2-11/16"
1½"	15030FXF	OC - carbon steel	5.0	5-7/16"	3-15/32"
		OS - stainless steel	5.6		
		AL - aluminum	1.7		
		BR - brass	5.2	4-11/16"	3"
		MI - malleable iron	4.6		
2"	230FXF	OC - carbon steel	7.6	6-21/32"	3-1/4"
		OS - stainless steel	6.3		
		AL - aluminum	4.1		
		BR - brass	9.9	6-3/16"	2-7/8"
		MI - malleable iron	8.8		
3"	330FXF	OC - carbon steel	13.4	8-9/64"	4-13/16"
		OS - stainless steel	13.2		
		AL - aluminum	5.2		
		BR - brass	15.4	7-1/16"	3-7/8"
		MI - malleable iron	13.0		
4"	430FXF	AL - aluminum	9.2	9-1/8"	4-3/4"

Swivels are shipped standard with the following components:

- *Buna-N* for pressure seals and dust seals
- *Carbon steel* for ball bearings

Single Plane O-Ring Style 30 150# ASA Flange x 150# ASA Flange

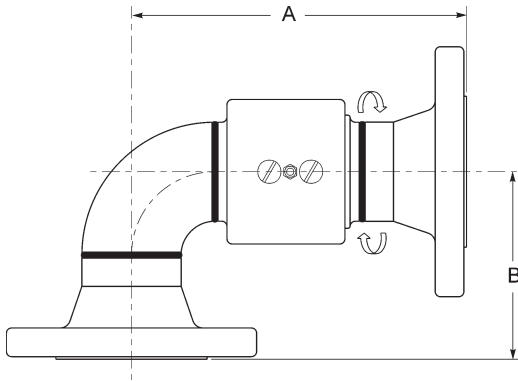

Size	Part #	Material	Weight (lbs)	Dimensions (inches)	
				A	B
1"	130FGXFG	OC - carbon steel	---	6-3/32"	3-3/16"
		OS - stainless steel	---	6-19/32"	3-11/16"
1½"	15030FGXFG	OC - carbon steel	---	7-7/8"	4-11/16"
		OS - stainless steel	---	7-1/32"	5-11/32"
		AL - aluminum	---	7-1/32"	5-11/32"
2"	230FGXFG	OC - carbon steel	20.20	8-1/32"	4-1/2"
		OS - stainless steel	20.20	8-5/8"	5-9/32"
		AL - aluminum	---	8-5/8"	5-9/32"
3"	330FGXFG	OC - carbon steel	32.90	9-7/8"	5-3/4"
		OS - stainless steel	32.90	9-11/16"	6-15/32"
		AL - aluminum	12.80	11-31/32"	7-19/32"
4"	430FGXFG	AL - aluminum	14.00	11-31/32"	7-19/32"

Tank Truck Flange x Tank Truck Flange

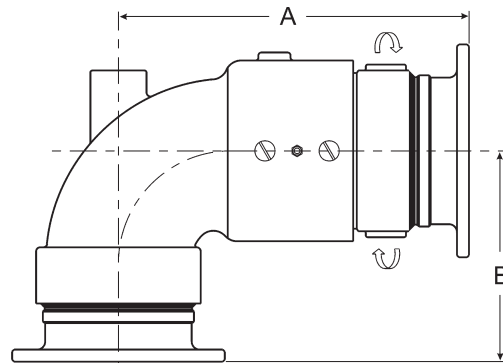

Size	Part #	Material	Weight (lbs)	Dimensions (inches)	
				A	B
2"	230TFXTF	OC - carbon steel	---	---	---
		OS - stainless steel	---	---	---
		AL - aluminum	---	---	---
3"	330TFXTF	OC - carbon steel	---	---	---
		OS - stainless steel	---	8-3/4"	5-9/16"
		AL - aluminum	---	10-15/16"	6-9/16"
4"	430TFXTF	AL - aluminum	12.00	10-15/16"	6-9/16"

Single Plane O-Ring Style 40 Female NPT x Female NPT

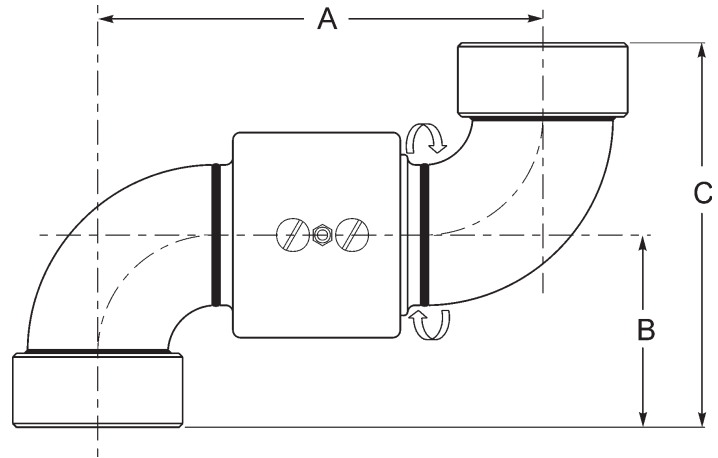

Size	Part #	Material	Weight (lbs)	Dimensions (inches)		
				A	B	C
1"	140FXF	OC - carbon steel	4.4	4-59/64"	2-3/16"	4-3/8"
		OS - stainless steel		5-59/64"	2-11/16"	5-3/8"
1½"	15040FXF	OC - carbon steel	---	7-11/16"	3-15/32"	6-15/16"
		OS - stainless steel	7.0			
		AL - aluminum	2.3			
		BR - brass	6.8	6-1/8"	3"	6"
		MI - malleable iron	6.2			
2"	240FXF	OC - carbon steel	8.5	7-17/32"	3-1/4"	6-1/2"
		OS - stainless steel	---			
		AL - aluminum	4.5			
		BR - brass	11.2	6-11/16"	2-7/8"	5-3/4"
		MI - malleable iron	9.1			
3"	340FXF	OC - carbon steel	17.7	10-1/8"	4-13/16"	9-5/8"
		OS - stainless steel	---			
		AL - aluminum	5.9			
		BR - brass	18.0	8-1/4"	3-7/8"	7-3/4"
		MI - malleable iron	15.0			
4"	440FXF	AL - aluminum	10.2	10-5/8"	4-3/4"	9-1/2"

Swivels are shipped standard with the following components:

- *Buna-N* for pressure seals and dust seals
- *Carbon steel* for ball bearings

Single Plane O-Ring Style 40 150# ASA Flange x 150# ASA Flange

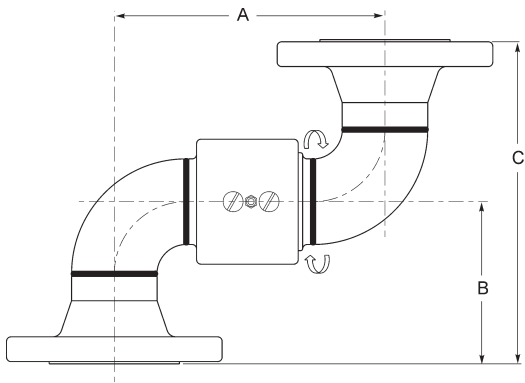

Size	Part #	Material	Weight (lbs)	Dimensions (inches)		
				A	B	C
1"	140FGXFG	OC - carbon steel	8.90	4-59/64"	3-3/16"	6-3/8"
		OS - stainless steel	8.90	5-59/64"	3-11/16"	7-3/8"
1½"	15040FGXFG	OC - carbon steel	---	7-11/16"	4-11/16"	9-3/8"
		OS - stainless steel	---	---	---	---
		AL - aluminum	---	6-1/8"	5-11/32"	5-11/16"
2"	240FGXFG	OC - carbon steel	21.10	7-17/32"	4-1/2"	9"
		OS - stainless steel	21.10	---	---	---
		AL - aluminum	---	6-11/16"	5-9/32"	10-9/16"
3"	340FGXFG	OC - carbon steel	39.70	10-1/8"	5-3/4"	11-1/2"
		OS - stainless steel	39.70	---	---	---
		AL - aluminum	11.00	8-1/4"	6-5/8"	13-1/4"
4"	440FGXFG	AL - aluminum	---	10-5/8"	7-9/16"	15-1/8"

Tank Truck Flange x Tank Truck Flange

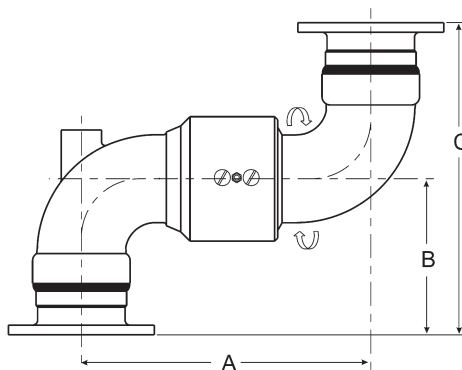

Size	Part #	Material	Weight (lbs)	Dimensions (inches)		
				A	B	C
2"	240TFXTF	OC - carbon steel	---	---	---	---
		OS - stainless steel	---	---	---	
		AL - aluminum	---	---	---	
3"	340TFXTF	OC - carbon steel	---	---	---	---
		OS - stainless steel	---	---	---	
		AL - aluminum	7.3	8-1/4"	5-9/16"	11-1/8"
4"	440TFXTF	AL - aluminum	17.0	10-5/8"	6-9/16"	13-1/8"

Double Plane O-Ring Style 50 Female NPT x Female NPT

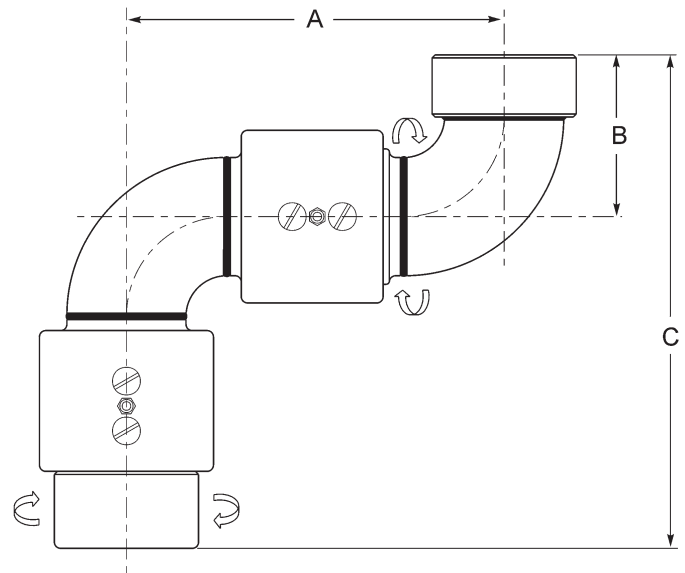

Size	Part #	Material	Weight (lbs)	Dimensions (inches)		
				A	B	C
1"	150FXF	OC - carbon steel	7.30	4-59/64"	2-3/16"	6-3/32"
		OS - stainless steel	7.30	5-59/64"	2-11/16"	7-19/32"
1½"	15050FXF	OC - carbon steel	9.00	7-11/16"	3-15/32"	8-29/32"
		OS - stainless steel	9.00	6-1/8"	3"	7-11/16"
		AL - aluminum	---	7-17/32"	3-1/4"	9-29/32"
2"	250FXF	OC - carbon steel	---	6-11/16"	2-7/8"	9-1/16"
		OS - stainless steel	---	10-1/8"	4-13/16"	12-61/64"
		AL - aluminum	7.80	8-1/4"	3-7/8"	10-29/32"
		BR - brass	14.90	10-5/8"	4-3/4"	13-7/8"
3"	350FXF	MI - malleable iron	13.20			
		OC - carbon steel	21.80			
		OS - stainless steel	21.80			
		AL - aluminum	9.40			
4"	450FXF	MI - malleable iron	21.50			
		AL - aluminum	15.00			

Swivels are shipped standard with the following components:

- *Buna-N* for pressure seals and dust seals
- *Carbon steel* for ball bearings

Double Plane O-Ring Style 50 150# ASA Flange x 150# ASA Flange

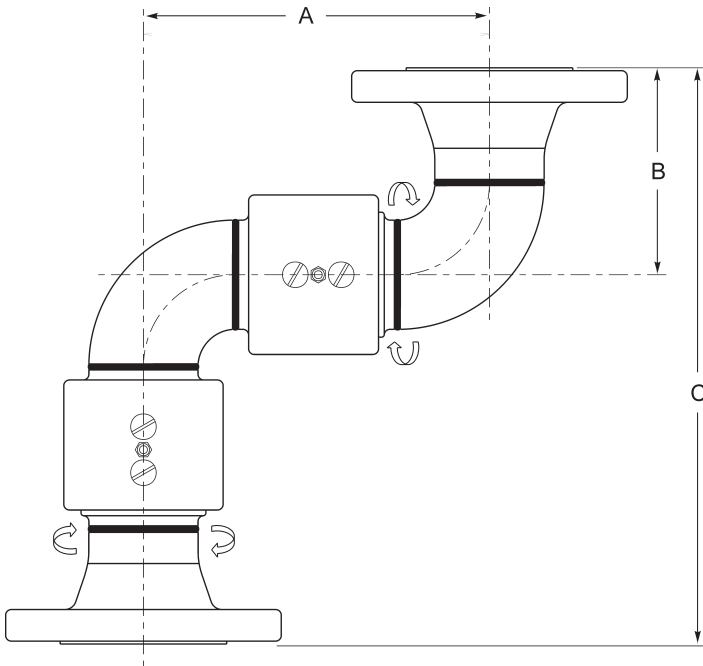

Size	Part #	Material	Weight (lbs)	Dimensions (inches)		
				A	B	C
1"	150FGXFG	OC - carbon steel	---	4-59/64"	3-3/16"	9-19/64"
		OS - stainless steel	---	5-59/64"	3-11/16"	10-19/64"
1½"	15050FGXFG	OC - carbon steel	---	7-11/16"	4-11/16"	12-9/16"
		OS - stainless steel	---	6-1/8"	5-11/32"	12-3/8"
		AL - aluminum	---	7-17/32"	4-1/2"	12-17/32"
2"	250FGXFG	OC - carbon steel	---	6-11/16"	5-9/32"	13-29/32"
		OS - stainless steel	---	10-1/8"	5-3/4"	15-5/8"
3"	350FGXFG	OC - carbon steel	---	8-1/4"	6-15/32"	16-3/32"
		OS - stainless steel	---	10-5/8"	7-19/32"	19-9/16"
		AL - aluminum	---			
4"	450FGXFG	AL - aluminum	---			

Swivels are shipped standard with the following components:

- *Buna-N* for pressure seals and dust seals
- *Carbon steel* for ball bearings

Double Plane O-Ring Style 60 Female NPT x Female NPT

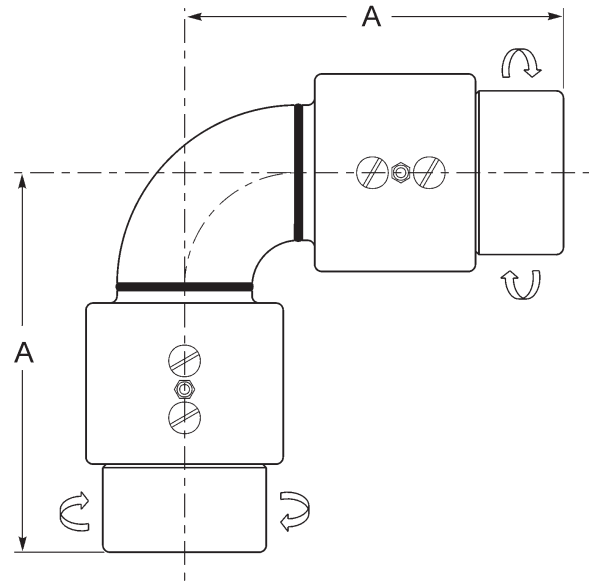

Size	Part #	Material	Weight (lbs)	Dimensions (inches)
				A
1"	160FXF	OC - carbon steel	7.00	4-13/32"
		OS - stainless steel	---	4-29/32"
1½"	15060FXF	OC - carbon steel	---	5-7/16"
		OS - stainless steel	7.70	---
		AL - aluminum	---	4-11/16"
2"	260FXF	OC - carbon steel	12.30	6-21/32"
		OS - stainless steel	12.30	---
		AL - aluminum	6.90	---
		BR - brass	14.30	6-7/32"
		MI - malleable iron	---	---
3"	360FXF	OC - carbon steel	19.40	8-9/64"
		OS - stainless steel	---	---
		AL - aluminum	8.60	7-1/32"
		MI - malleable iron	18.60	---
4"	460FXF	AL - aluminum	13.40	9-1/8"

Swivels are shipped standard with the following components:

- *Buna-N* for pressure seals and dust seals
- *Carbon steel* for ball bearings

Double Plane O-Ring Style 60 150# ASA Flange x 150# ASA Flange

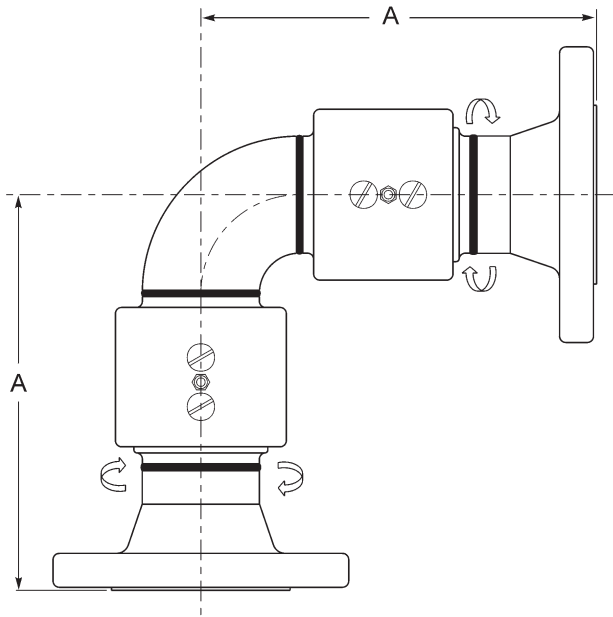

Size	Part #	Material	Weight (lbs)	Dimensions (inches)
				A
1"	160FGXFG	OC - carbon steel	---	6-7/64"
		OS - stainless steel	---	6-39/64"
1½"	15060FGXFG	OC - carbon steel	---	7-7/8"
		OS - stainless steel	---	7-1/32"
		AL - aluminum	---	
2"	260FGXFG	OC - carbon steel	24.90	8-1/32"
		OS - stainless steel	24.90	8-5/8"
		AL - aluminum	---	
3"	360FGXFG	OC - carbon steel	---	9-7/8"
		OS - stainless steel	---	9-5/8"
		AL - aluminum	---	
4"	460FGXFG	AL - aluminum	---	11-31/32"

Swivels are shipped standard with the following components:

- *Buna-N* for pressure seals and dust seals
- *Carbon steel* for ball bearings

Triple Plane O-Ring Style 70 Female NPT x Female NPT

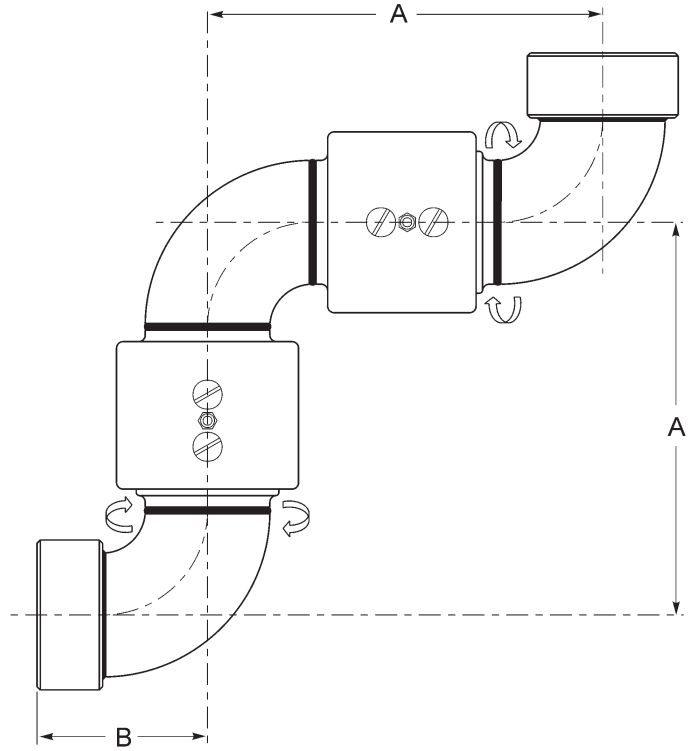

Size	Part #	Material	Weight (lbs)	Dimensions (inches)	
				A	B
1"	170FXF	OC - carbon steel	7.60	4-59/64"	2-3/16"
		OS - stainless steel	---	5-59/64"	2-11/16"
1½"	15070FXF	OC - carbon steel	---	7-11/16"	3-15/32"
		OS - stainless steel	---	6-1/8"	3"
		AL - aluminum	3.80	7-17/32"	3-1/4"
2"	270FXF	OC - carbon steel	16.40	6-11/16"	2-7/8"
		OS - stainless steel	---	10-1/8"	4-13/16"
		AL - aluminum	7.80	8-1/4"	3-7/8"
		BR - brass	---	10-5/8"	4-3/4"
		MI - balleable iron	---		
3"	370FXF	OC - carbon steel	---		
		OS - stainless steel	---		
		AL - aluminum	10.10		
4"	470FXF	AL - aluminum	16.70		

Swivels are shipped standard with the following components:

- *Buna-N* for pressure seals and dust seals
- *Carbon steel* for ball bearings

Triple Plane O-Ring Style 70 150# ASA Flange x 150# ASA Flange

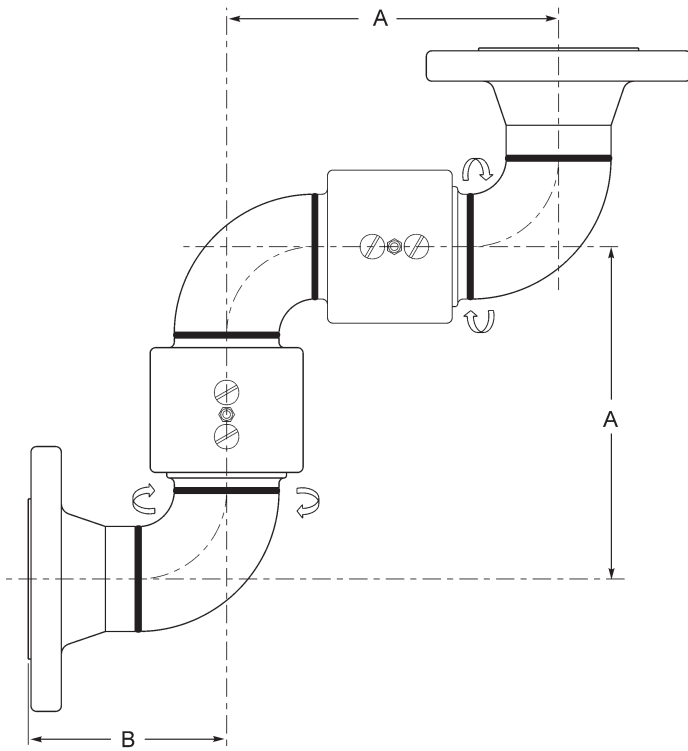

Size	Part #	Material	Weight (lbs)	Dimensions (inches)	
				A	B
1"	170FGXFG	OC - carbon steel	---	4-59/64"	3-3/16"
		OS - stainless steel	---	5-59/64"	
1½"	15070FGXFG	OC - carbon steel	---	7-11/16"	4-11/16"
		OS - stainless steel	---	6-1/8"	5-11/32"
		AL - aluminum	---	7-17/32"	4-1/2"
2"	270FGXFG	OC - carbon steel	---	6-11/16"	5-9/32"
		OS - stainless steel	---	10-1/8"	5-3/4"
		AL - aluminum	---	8-1/4"	6-15/32"
3"	370FGXFG	OC - carbon steel	---	10-5/8"	7-19/32"
		OS - stainless steel	---		
4"	470FGXFG	AL - aluminum	---		

Swivels are shipped standard with the following components:

- *Buna-N* for pressure seals and dust seals
- *Carbon steel* for ball bearings

Corrosion Resistance of Coupling Material

Caution



The following data has been compiled from generally available sources and should not be relied upon without consulting and following the specific recommendations of the manufacturer regarding particular coupling materials.

Ratings

Metal	Non-Metal	Gasket/Seal Material
1 - excellent 2 - good 3 - fair X - not recommended -- contact factory	A - acceptable X - not recommended -- contact factory	T - PTFE V - FKM E - EPDM, EPR N - Neoprene B - Buna N

- Note:
1. Ratings given are based at 70°F. Chemical compatibility varies greatly with temperature. For applications at temperatures other than 70°F, contact the factory for recommendations.
 2. Gasket / seal materials are not necessarily listed in order of preference.
 3. Chemical resistance of a material does not necessarily indicate the suitability of a fitting in a given application due to variables such as improper clamp and coupling application, special hose construction, gasket material, etc.



Special caution should be taken when handling hazardous materials.

AGENT	Aluminum	Brass	Malleable Iron Carbon Steel	Stainless Steel, 316	Seal Material
Acetate Solvents (Crude)	1	X	2	1	T
Acetate Solvents (Pure)	1	1	X	1	T
Acetic Acid (80%)	3	X	X	1	TEVNB
Acetic Acid (50%)	2	X	X	1	TEVNB
Acetic Acid (20%)	2	X	X	1	TEVNB
Acetic Acid (10%)	2	X	X	1	TEVNB
Acetic Anhydride	2	X	2	2	TNB
Acetone	1	2	2	1	TE
Acetylene	1	X	2	1	TEVNB
Alcohols					
Amyl Alcohol	2	2	2	2	TEVNB
Benzyl Alcohol	2	2	2	1	TVB
Butyl Alcohol	1	2	2	1	TEVN
Diacetone Alcohol	1	1	2	2	TE
Ethyl Alcohol	1	2	2	2	TEVNB
Hexyl Alcohol	-	-	-	-	-
Isobutyl Alcohol	-	-	-	-	-
Isopropyl Alcohol	2	2	2	2	TEVNB
Methyl Alcohol (Methanol)	2	2	2	2	TENB
Octyl Alcohol	-	-	-	-	-
Propyl Alcohol	2	2	2	1	TEVNB
Aluminum					
Aluminum Chloride (Aqu.)	X	X	X	X	TEVNB
Aluminum Fluoride (Sat.)	2	-	X	2	TEVNB
Aluminum Nitrate (Sat.)	3	X	X	2	TEVNB
Aluminum Potassium Sulfate (Alum)	2	2	X	2	TEVNB
Aluminum Sulfate (Sat.)	X	X	X	2	TEVNB
Ammonia					
Ammonia Anhydrous	1	X	1	1	TENB
Ammonia Gas	X	X	1	1	TENB
Ammonia Nitrate	-	-	-	-	-
Ammonium					
Ammonium Bifluoride	-	X	X	-	TEVB
Ammonium Carbonate (Sat.)	2	X	2	2	TEVNB
Ammonium Casenate	-	-	-	-	-
Ammonium Chloride (Sat.)	X	X	X	X	TEVNB
Ammonium Hydroxide (Sat.)	2	X	1	2	TEVNB
Ammonium Nitrate	2	X	X	-	TENB
Ammonium Phosphate (10-40%)	X	X	X	2	TEVNB
Ammonium Sulfate (10-40%)	X	X	X	2	TEVNB
Aniline	-	X	X	1	TV
Arsenic Acid	X	X	X	2	TEVNB
Asphalt	-	-	2	2	TV
Barium					
Barium Carbonate (Sat.)	X	2	2	2	TEVNB
Barium Chloride (Sat.)	-	2	-	-	TEVNB
Barium Hydroxide (Sat.)	X	2	2	2	TEVNB
Barium Sulfate	2	2	X	2	TEVNB
Barium Sulfide	X	X	2	2	TEVNB
Beer	1	2	2	1	TEVNB
Benzaldehyde	2	2	X	2	TE
Benzene, Benzol	1	2	2	2	TV
Benzine	-	-	-	-	-
Benzoic Acid	2	2	X	2	TVN
Black Liquor	X	X	-	2	TEVNB
Bleach (12.5% Active Chlorine)	X	-	X	X	TEVN
Borax	X	2	2	1	TEVNB
Boric Acid	1	X	X	-	TEVNB
Brine Acid	-	2	-	-	TEVNB
Bromic acid	X	X	-	-	TEVN
Bromine Liquid	2	-	-	X	TV
Butadiene, Butylene	2	2	2	2	TVNB
Butane	2	2	1	2	TV
Butyl Acetate	1	2	2	2	T
Butyric Acid	2	2	X	2	TV

Ratings given are based at 70°F

AGENT	Aluminum	Brass	Malleable Iron Carbon Steel	Stainless Steel, 316	Seal Material
Calcium					
Calcium Bisulfate	X	-	X	2	T
Calcium Bisulfide	-	-	-	2	TVB
Calcium Bisulfite	X	X	X	2	TVNB
Calcium Bromide	X	2	X	X	T
Calcium Carbonate	X	2	2	2	TEVB
Calcium Chloride (Sat.)	-	2	2	-	TEVNB
Calcium Hydroxide (Sat.)	X	2	2	2	TEVNB
Calcium Hypochlorite (Sat.)	X	X	X	2	TEV
Carbon					
Carbon Bisulfide	1	X	2	2	TV
Carbon Dioxide (Dry)	1	1	2	2	TENB
Carbon Dioxide (Wet)	1	X	3	2	TENB
Carbon Disulfide	1	X	2	2	TV
Carbon Monoxide	1	1	2	1	TEVNB
Carbon Tetrachloride	X	-	2	-	TV
Carbonic Acid	1	2	2	2	TEVNB
Castor Oil	2	2	2	2	TEVNB
Caustic Potash	X	-	X	2	TEVNB
Cellosolves	2	2	2	2	TE
Chlorine (Liquid)	-	-	2	3	TV
Chloroform	-	-	X	-	TV
Chlorosulfonic Acid	-	X	2	X	T
Clorox (Bleach, 5.5% CL)	X	-	X	2	TEVB
Chromic Acid (50%)	2	X	X	-	TVNB
Citric Acid	3	X	X	-	TEVNB
Coke Oven Gas	2	3	2	2	TEVN
Copper					
Copper Chloride	X	X	X	X	TEVNB
Copper Cyanide	X	X	-	2	TEVNB
Copper Sulfate	X	X	X	2	TEVNB
Crylic Acid (Conc.)	2	2	2	2	TEV
Cyclohexane	2	2	2	2	TVB
Detergents	2	2	2	2	TEVNB
Dextrose	2	-	-	-	TEVNB
Diesel Fuels	1	1	2	1	TVB
Diethylamine	2	-	X	2	TN
Disodium Phosphate	-	-	1	1	TEV
Ethers	2	2	2	1	TB
Ethyl					
Ethyl Acetate	-	-	2	2	T
Ethyl Chloride	-	-	2	1	TEVB
Ethylene					
Ethylene Chloride	-	-	2	-	TV
Ethylene Dichloride	-	2	2	2	TV
Ethylene Glycol	1	2	2	2	TEVNB
Ethylene Oxide	1	X	2	2	T
Fatty Acids	1	3	X	1	TVNB
Ferric					
Ferric Chloride	X	X	X	X	TEVNB
Ferric Hydroxide	-	-	-	1	TEVNB
Ferric Nitrate (10-50%)	X	X	X	2	TEVNB
Ferric Sulfate	X	X	X	-	TEVNB
Ferrous					
Ferrous Chloride (Sat.)	X	X	-	X	TEVNB
Ferrous Sulfate	2	2	X	-	TEVNB
Fluboric Acid	X	-	1	-	TEVNB
Formaldehyde (50%)	-	2	X	1	TEN
Formic Acid (Anhyd.)	1	X	X	-	TEVN
Freon					
Freon 11	2	2	X	2	TVNB
Freon 12	2	2	X	2	TVNB
Freon 22	2	2	X	2	TN
Fruit Juices	2	2	X	2	TVNB
Fuel Oil	2	2	2	2	TVNB

Ratings given are based at 70°F

AGENT	Aluminum	Brass	Malleable Iron Carbon Steel	Stainless Steel, 316	Seal Material
Furfural	2	2	2	2	TEN
Gasoline					
Refined Gasoline	2	2	2	2	TVNB
Sour Gasoline	X	2	2	2	TVNB
Gelatin	2	2	X	2	TEVNB
Glucose	2	2	2	2	TEVNB
Glue	2	2	2	2	TEVNB
Glycerine	1	1	2	1	TEVNB
Glycols	2	2	2	2	TEVNB
Green Liquor	-	-	2	-	TEVNB
Heptane	2	2	2	2	TVNB
Hexane	2	2	2	1	TVNB
Hydrobromic Acid (50%)	X	X	X	X	TEV
Hydrobromic Acid (20%)	X	X	X	X	TEV
Hydrochloric Acid (20%)	X	X	X	X	TEVNB
Hydrochloric Acid (38%)	X	X	X	X	TEVN
Hydrocyanic Acid	2	X	2	2	TEVN
Hydrofluosilicic Acid (10-50%)	X	2	X	2	TEVNB
Hydrogen					
Hydrogen Peroxide (50%)	-	X	X	-	TEV
Hydrogen Sulfide (Aq.)	-	-	-	2	TE
Hydrogen Chloride (Dry Gas)	X	2	2	-	TEVN
Hydrogen Gas	1	1	-	1	TEVNB
Hypochlorous Acid	X	X	X	X	TEV
Iodine	1	X	X	X	TEV
Isopropyl Ether	-	2	-	2	T
Jet Fuel (JP4, JP5)	2	1	2	2	TV
Kerosene	2	2	2	2	TVNB
Ketones	2	2	2	2	T
Lactic Acid (25%)	3	2	X	-	TEVN
Lactic Acid (80%)	2	2	X	-	TEVN
Lard Oil	2	-	3	2	TVB
Lead					
Lead Acetate	X	X	X	2	TENB
Lead Chloride	X	-	-	2	TVNB
Lead Sulfate	X	-	X	2	TEVNB
Lime Sulphur	X	X	X	2	TEVN
Linoleic Acid	2	X	X	2	TVB
Linseed Oil	2	2	2	2	TVNB
Lubricants (Oil)	2	1	2	2	TVNB
Magnesium					
Magnesium Carbonate	2	-	-	2	TEVNB
Magnesium Chloride	X	X	-	-	TEVNB
Magnesium Hydroxide	2	2	2	1	TEVNB
Magnesium Nitrate	2	2	2	2	TEVNB
Magnesium Oxide	-	-	-	-	-
Magnesium Sulfate	2	-	-	2	TEVNB
Maleic Acid	-	2	X	2	TEV
Mercuric					
Mercuric Chloride	X	X	X	-	TEVB
Mercuric Cyanide	X	X	X	2	TEVB
Mercury	X	X	2	1	TEVNB
Methane	1	1	2	1	TEVNB
Methanol	2	2	2	2	TENB
Methyl					
Methyl Bromide	X	-	2	2	TV
Methyl Ethyl Ketone	2	2	2	2	TE
Methyl Isobutyl Ketone	2	2	2	2	T
Methyl Methacrylate	2	-	X	2	T
Methylene Chloride	-	2	2	-	T
Milk	1	X	2	1	TEVNB
Mineral Oil	2	1	2	2	TVNB
Muriatic Acid	X	-	-	X	TV
Napthalene	2	2	2	1	TV
Naptha	2	2	2	2	TVB

Ratings given are based at 70°F

AGENT	Aluminum	Brass	Malleable Iron Carbon Steel	Stainless Steel, 316	Seal Material
Nickel					
Nickel Chloride	X	X	X	-	TEVNB
Nickel Sulfate	X	X	-	2	TEVNB
Nitric					
Nitric Acid (100%)	1	X	X	-	TV
Nitric Acid (50%)	X	X	X	-	TV
Nitric Acid (30%)	X	X	X	-	TV
Nitrobenzene	1	2	2	2	T
Oils					
Castor Oil	2	2	2	2	TEVNB
Coconut Oil	2	-	3	2	TVB
Corn Oil	2	2	2	2	TVNB
Cotton Seed Oil	2	2	2	2	TVNB
Fuel Oil	2	2	2	2	TVNB
Linseed Oil	2	2	2	2	TVNB
Mineral Oil	2	1	2	2	TVNB
Silicon Oil	2	1	2	2	TEVB
Vegetable Oil	2	2	2	1	TVNB
Oleic Acid	2	3	2	1	TB
Oleum	2	X	2	2	TV
Oxalic Acid (Sat.)	2	-	X	X	TEV
Oxygen	2	2	2	2	TEVNB
Palmitic Acid (Sat.)	2	3	3	2	TVB
Paraffin	2	2	2	2	TVNB
Perchloroethylene	2	2	2	-	TV
Petrolatum	2	-	3	2	TVNB
Phenol (Carbolic Acid)	1	1	2	1	TV
Phosphoric Acid					
Phosphoric Acid (25-50%)	X	X	X	-	TEVN
Phosphoric Acid (50-85%)	X	X	X	-	TEV
Photographic Solutions	-	-	X	1	TVNB
Phthalic Anhydride	-	2	2	1	TEV
Picric Acid	1	X	X	2	TEVNB
Plating Solutions					
Brass Plating Solution	-	-	-	2	TEVNB
Cadmium Plating Solution	-	-	-	2	TEVNB
Chrome 40% Plating Solution	X	2	X	2	TEVN
Copper (Cyanide) Plating Solution	-	-	-	-	TEVNB
Gold Plating Solution	-	-	-	1	TEVNB
Iron Plating Solution	-	-	-	-	TEVB
Lead Plating Solution	-	-	-	1	TEVNB
Nickel Plating Solution	-	-	-	1	TEVNB
Silver Plating Solution	-	-	-	1	TEVNB
Tin Plating Solution	-	-	-	3	TEVNB
Zinc Plating Solution	-	-	-	-	TEVNB
Potassium					
Potassium Acetate	X	X	2	-	TEVB
Potassium Bicarbonate (30%)	X	2	2	1	TEVNB
Potassium Carbonate (50%)	X	2	2	1	TEVNB
Potassium Chlorate (30%)	2	X	2	1	TEVNB
Potassium Chloride (30%)	X	X	2	-	TEVNB
Potassium Chromate (30%)	2	2	-	2	TEVB
Potassium Cyanide Solution (30%)	X	X	2	2	TEVNB
Potassium Dichromate (30%)	1	2	2	1	TEVB
Potassium Hydroxide (90%)	X	X	-	-	TENB
Potassium Nitrate (80%)	1	2	2	2	TEVNB
Potassium Permanganate (20%)	2	2	2	2	TEVN
Potassium Sulfate (10%)	1	2	2	1	TEVNB
Propane	1	1	2	2	TVB
Propylene Glycol	2	2	2	2	TVNB
Propylene Oxide (90%)	-	-	-	1	TE
Pyridine	2	2	2	2	T
Pyrogalllic Acid	2	2	2	2	TVNB
Silver Nitrate	X	X	X	1	TEVNB
Soap Solutions	2	2	2	2	TEVNB

Ratings given are based at 70°F

AGENT	Aluminum	Brass	Malleable Iron Carbon Steel	Stainless Steel, 316	Seal Material
Sodium					
Sodium Acetate	1	2	X	2	TEN
Sodium Bicarbonate (20%)	2	2	3	1	TEVNB
Sodium Bisulfate	X	-	2	-	TEVNB
Sodium Bisulfite	X	2	X	-	TEVNB
Sodium Borate	2	2	3	2	TEVNB
Sodium Perborate (10%)	2	X	2	2	TEVNB
Sodium Carbonate	X	2	2	2	TEVNB
Sodium Chlorate (50%)	2	2	X	2	TEVNB
Sodium Cyanide	X	X	2	-	TEVNB
Sodium Dichromate	2	X	2	2	TE
Sodium Hydroxide (70%)	X	X	3	2	TENB
Sodium Hydroxide (50%)	X	X	3	-	TENB
Sodium Hydroxide (30%)	X	2	2	1	TENB
Sodium Chloride (30%)	X	2	2	-	TEVNB
Sodium Hypochlorite	X	X	X	-	TEV
Sodium Metaphosphate	X	X	X	2	TEVNB
Sodium Nitrate (40%)	1	2	2	1	TENB
Sodium Perborate (10%)	2	X	2	2	TEVNB
Sodium Peroxide (10%)	2	X	2	2	TEVNB
Sodium Silicate	1	2	2	2	TEVNB
Sodium Sulfate	-	2	2	1	TEVNB
Sodium Sulfide (50%)	X	X	2	2	TEVNB
Sodium Thiosulphate	2	X	X	2	TEVNB
Stannic Chloride	X	X	X	X	TEVNB
Stannous Chloride	X	X	X	-	TEVNB
Steam	-	-	-	-	-
Stearic Acid	2	3	3	1	TVNB
Stoddard's Solvent	2	2	2	2	TVB
Sugar Liquors (Cane)	1	2	2	2	TEVNB
Sugar Liquors (Beet)	1	2	2	1	TEVNB
Sulfate Liquors	2	X	3	2	TVNB
Sulfite Liquors	X	X	X	2	TVNB
Sulfur Chloride	X	-	X	-	TV
Sulfur Dioxide (Dry)	2	2	1	2	TE
Sulfur Trioxide	2	2	2	2	TEV
Sulfuric Acid (TO 10%)	X	2	X	X	TEVNB
Sulfuric Acid (100%)	X	X	2	-	TV
Sulfurous Acid	2	2	X	-	TV
Tannic Acid	X	-	X	2	TEVNB
Tanning Liquors	1	-	-	1	TVNB
Tartaric Acid	-	-	-	1	TVNB
Titanium Tetrachloride	X	X	2	2	TV
Toluene	1	1	1	1	TVB
Tetrahydrofuran	X	-	1	2	T
Tomato Juice	2	-	3	2	TEVNB
Trichloroethylene	1	-	2	-	TV
Triethanolamine	2	X	2	2	TEVN
Triethylamine	-	-	-	2	TVB
Trisodium Phosphate (10%)	X	2	2	1	TVNB
Turpentine	2	X	2	1	TVB
Urea (50%)	2	-	2	2	TEVNB
Urine	-	-	2	1	TEVNB
Vinegar	2	X	2	2	TEVN
Water Acid (Mine)	X	X	X	-	TEVNB
Water (Distilled)	X	2	X	2	TEVNB
Water (Sea)	2	2	X	2	TEVNB
Whiskey	X	2	2	1	TEVNB
White Liquor (Pulp)	2	-	X	2	TEVNB
Wine	X	2	X	1	TEVNB
Xylene	2	2	2	2	TV
Zinc					
Zinc Chloride	X	X	X	2	TEVNB
Zinc Nitrate	-	-	-	2	TEVNB
Zinc Sulfate (50%)	X	2	X	1	TEVNB

Ratings given are based at 70°F

Dixon, founded in 1916, is a premier manufacturer and supplier of hose couplings, valves, dry-disconnects, swivels, and other fluid transfer and control products. The company's global reach includes a wide range of products for numerous industries including petroleum exploration, refining, transportation, chemical processing, food & beverage, steel, fire protection, construction, mining and manufacturing. Dixon's strategic objective is to create solutions that make products safer, leak-free, longer lasting, and always available.

dixonvalve.com • *Customer Service: 877.963.4966*



The Right Connection®

Dixon Valve

800 High Street, Chestertown, MD 21620

Fax: 800.283.4966



Customer Service



Facebook